

MARCH/APRIL 2011

Volume 7 Number 2

# AQUA CULTURE

A s i a P a c i f i c



**E**ffective feeding in shrimp culture  
**D**evelopments in extrusion  
**R**apid method for *in vitro* protein digestibility  
**H**igh health marine fish fry from Singapore  
**G**rouper deformities in India

# Grow with Gold Coin



Since 1984,  
GOLD COIN is committed to  
research, sustainability and  
good customer service.

visit our website  
[www.goldcoin-group.com](http://www.goldcoin-group.com)

At **GOLD COIN**, we are committed to provide superior shrimp feeds to ensure your business success. Using only the highest quality raw materials and manufactured under strict quality controls, we offer a range of feeds\* to consistently meet the various levels of production systems. Our strict policy of opposing the use of antibiotics in our feed is congruent with the growing demand by consumers for traceability.

- **GOLD SUPREME** for superior growth and feed efficiency. Health enhancement with proprietary ENCAP® Immune enhancer
- **GOLD FORTE/GOLD VERTEX** are specially formulated for the intensive culture of white shrimp *Penaeus vannamei* in Asian conditions
- **GOLD CLASSIC/GOLD ELITE** are our flagship products that meet all nutrient requirements of *Penaeus monodon* shrimp under normal conditions
- **GOLD ROYALE** is used in highly intensive conditions by the most discerning farmer
- **ENCAP®** Hatchery Feeds have prime quality ingredients micro-encapsulated within a digestible yet water stable membrane

\*Some products may not be available in your country. For details on Gold Coin range of shrimp feed and other Gold Coin Aquaculture products, please contact our regional offices.

**HEADQUARTERS** - Gold Coin Holding Limited Sdn Bhd. Suite 9-6, Level 9, Wisma UOA Damansara II No.6 Jalan Changkat Semantan Damansara Heights 50490, Kuala Lumpur, Malaysia Tel: +603 2092 1999 Fax: +603 2092 1919 email: [general@goldcoin-group.com](mailto:general@goldcoin-group.com)

**MALAYSIA (JOHOR)** - Gold Coin Specialities Sdn Bhd/Gold Coin Biotechnologies Sdn Bhd, Tel: +607 237 0695 Fax: +607 236 1143 email: [sp.koh@goldcoin-my.com](mailto:sp.koh@goldcoin-my.com)

**INDONESIA (NORTH SUMATRA)** - P.T. Gold Coin Specialities Medan, Tel: +62 61 685 5127 Fax: +62 61 685 3452, email: [p.zulkarnain@goldcoin-id.com](mailto:p.zulkarnain@goldcoin-id.com)

**INDONESIA (WEST JAVA)** - P.T. Gold Coin Indonesia, Specialities Division, Tel: +62 21 885 3668 Fax: 62 21 884 1947 email: [p.zulkarnain@goldcoin-id.com](mailto:p.zulkarnain@goldcoin-id.com)

**THAILAND (SONGKHLA)** - Gold Coin Specialities (Thailand) Co Ltd, Tel: +66 74 483 600/5 Fax: +66 74 483 493 email: [w.prapipat@goldcoin-th.com](mailto:w.prapipat@goldcoin-th.com)

**INDIA (CHENNAI)** - India- Gold Coin Biotechnologies Sdn. Bhd. India Liaison Office, No.1, B.V.R. Nagar, Alwar Thiru Nagar, Chennai 600087, India. Tel: +91 44 2486 8433 Fax: +91 44 2486 2091 email: [v.ravi@goldcoin-id.com](mailto:v.ravi@goldcoin-id.com)



## 2 From the editor

## 4 News

Taiwan grouper to China, shrimp vaccines, cobia to US markets

## 6 News in brief

## Shrimp Culture

### 8 Effective feeding in shrimp culture –an opinion article

Soraphat Panakorn says farmers should understand that feeding is influenced by the use of auto demand feeders and changing conditions.

## Feed Technology

### 14 New developments in extrusion

These include additions to existing products, new innovations and changing process control. By Mian N. Riaz

### 18 A rapid low-cost laboratory method for measuring *in vitro* protein digestibility of feed ingredients and feeds for shrimp.

Daniel Lemos and Albert G. J. Tacon propose a low cost solution for digestibility trials.

### 22 Dietary potassium diformate improves performance of white shrimp production under controlled conditions in Thailand

A promising alternative for modern shrimp nutrition. By Kai-J. Kühlmann, Orapint Jintasataporn and Christian Lückstädt

## Culture Technology

### 25 Understanding biofloc in aquaculture production systems

There is no universal set of guidelines but some consistent features are essential for success. By Stephen G. Newman

## Cage Culture

### 29 A Singapore contribution to a regional industry

MLA not only supplies high health fry and fingerlings but wants farmers to practise good farm management. By Zuridah Merican

### 32 Microdiets in sea bream larval production

Nick King, Philippe Dhert, Eamonn O'Brien and Brett Newman demonstrate the growth advantage by replacing *Artemia* during the early weaning of sea bream.

## Groupers in Asia

### 34 Grouper culture in peace agreement

In Tawi-Tawi Province, Philippines, high value groupers in cages are part of industrial-estate fish farming.

### 36 Deformities in tiger grouper in India

A description of morphological deformities common in tiger grouper produced in hatcheries. By Y.C. Thampi Samraj, P. Jayagopal, D. Thinesh Santhar, P.N. Damodar, and Michael A. Rimmer

## Marketing

### 38 The superior all male tilapia

In China, a fast growing and high flesh yield tilapia.

## Company News

### 39 Feed for juvenile fish/ Hainan's new tilapia feed mill

### 40 JSC in Vietnam for feed production

### 41 New company brand and premix plant in India

### 42 Game changing strategies/new algae facility

### 44 Safe shellfish/appointments

## Show Reviews

### 46 Asian Pacific Aquaculture 2011 in Kochi, India

Opportunities for shrimp, freshwater prawn and pangasius catfish aquaculture in India

### 52 Aquafair Malaysia 2010 in Kuala Lumpur

Progress for SMEs in the ornamental fish industry

## Book Review

### 54 Disease prevention in marine fish /The Shrimp Book

## Events

### 56 Third International Symposium on Cage Aquaculture in Asia & events listing

#### Editor/Publisher

**Zuridah Merican, PhD**

Tel: +603 2096 2275 Fax: +603 2096 2276

Email: zuridah@aquaaasiapac.com

#### Editorial Coordination

**Corporate Media Services P L**

Tel: +65 6327 8825/6327 8824

Fax: +65 6223 7314

Email: irene@corpmediapl.com

Web: www.corpmediapl.com

#### Design and Layout

**Words Worth Media Management Pte Ltd**

Email: sales@wordsworth.com.sg

Web: www.wworthmedia.com

AQUA Culture AsiaPacific is published bimonthly by **Aqua Research Pte Ltd**

3 Pickering Street, #02-36 Nankin Row, China Square Central, Singapore 048660

Web: www.aquaasiapac.com

Tel: +65 9151 2420 Fax: +65 6223 7314

Editorial and advertising enquiries  
Request for reprints and articles

Email: zuridah@aquaaasiapac.com

Tel: +603 2096 2275 Fax: +603 2096 2276

#### Subscriptions

Subscribe via the website at [www.aquaasiapac.com](http://www.aquaasiapac.com) or complete the enclosed form and mail with payment. Subscriptions can start at any time.

Subscriptions rate/year (6 issues): Asia SGD 70, Other zones: SGD 100

Email: subscribe@aquaaasiapac.com

Tel: +65 9151 2420 Fax: +65 6223 7314

Aqua Culture Asia Pacific Online  
View E-magazine  
Download past issues

Copyright © 2011 Aqua Research Pte Ltd. All rights reserved. No part of this publication may be reproduced, stored in a retrieval system or transmitted, in any form or by any means, electronic, mechanical, photocopying or otherwise, without the prior permission of the copyright owners.



## From the editor

### Living with Uncertainty? Efficiency may help!

Benjamin Franklin once said the only things certain in life are death and taxes (and certainly not the weather!). He made the point but I added the phrase in parenthesis. All over the world, weather, floods, drought and fires are causing not only misery to millions of people but seriously affecting crops and farming. FAO warned that the food index (based on their basket of food products) has reached a high and forecasts it to remain so, or even increase in the foreseeable future. To add fuel to fire (excuse the pun), the situation in the Middle East has pushed crude oil prices beyond the USD 100 per barrel mark again, last seen in 2008. This looks like a double whammy for inflation, but how does it affect the aquaculture industry?

The effect and immediate impact is the cost of feed. The prices of specific protein crops like corn and soy have increased significantly. Corn (CBOT) prices have increased 90% over the past 12 months while recent reports indicate that the adverse weather conditions will lower yields of soy in Brazil and result in slow planting in the US. Fires in Russia and floods in Australia have sent wheat prices rocketing. Fishmeal may soon be affected by higher fuel costs. The four raw materials just mentioned comprise more than 50% content of most aquaculture feed formulations. Something has to give - price or quality?

Modern aquaculture has the enormous responsibility of creating an alternative source of seafood to the dwindling capture fisheries, and this has to be done in a sustainable and economical manner. Unfortunately, none of us can say that the feeds used today for species in Asia are efficient. The best stress test would be to use least cost formulation in shrimp and fish feed diets but the result would be a failure. Least cost formulation requires matching the amino acid composition of various raw materials to meet the amino acid requirements of specific species. The role model is poultry feed. If this could be done, the requirement of 36% protein shrimp diets will not arise anymore.

To improve feed efficiency, we need to determine the nutrient requirements of specific species and avoid using the general term of shrimp feeds, marine fish feeds or freshwater fish feeds. The use of *P. monodon* diets for intensive *P. vannamei* farming (because of the former's higher protein content) is a case in point. A nutritionist questioned whether it was correct to reduce protein in feeds at the latter stages of culture, and if knowing more about the energy requirements would help in reducing feed costs. There are serious knowledge gaps in aquaculture nutrition that needs to be addressed urgently. With this need in mind, we would like to introduce **The Aquaculture Roundtable Series (TARS)**. To be held in Singapore on August 17-18 2011, the first in this annual series will focus on aqua feeds and nutrition (see page 28).

The objective of TARS is to provide a platform for multi-stakeholders (public and private sectors, academia and industry) to address pressing issues affecting this sector. The result is expected to be a self initiative to direct the development in a guided manner, yet allowing for 'thinking outside the box'. The benefit should come from the synergy of networking and creating efficiencies.

The recent increase in shrimp and fish prices due to strong demand may appear to be a saving grace for the industry but this is short term. This demand is expected to grow, which translates to higher consumption of the four raw materials mentioned above - the industry will then be back to square one. The only way forward is to improve efficiency and stop over-formulating for the species.

Zuridah Merican



### TARS 2011

AAP is pleased to announce the first of The Aquaculture Roundtable Series (TARS 2011). The inaugural meeting will be held in Singapore, 17-18 August, 2011. The focus will be Aquaculture Feeds and Nutrition.

### OUR MISSION

- We strive to be the beacon for the regional aquaculture industry.
- We will be the window to the world for Asia-Pacific aquaculture producers and a door to the market for international suppliers.
- We strive to be the forum for the development of self-regulation in the Industry

# NANOLIS

HIGH QUALITY FINGERLING FEED

made in Vietnam

*Has been presented in*

## AQUATIC ASIA 2011

Bitec, Bangkok. Thailand

Ask for a sample and discover our new micro feed under the NANOLIS range !



**Ocialis**  
Feeding a sustainable future

Tel : +33 2 97 48 54 76 - [ocialis@ocialis.evls.net](mailto:ocialis@ocialis.evls.net) - [www.ocialis.com](http://www.ocialis.com)

# More Taiwan grouper for China market

Taiwan is the world's leading producer of groupers. With the elimination of import tariffs for live groupers, under the Taiwan-China ECFA, Taiwan producers look forward to higher demand from China. The government is expecting an annual growth of 20%.

Since 2007, the annual production has been 17,000 tonnes. In the next 4 years, the target is to double production. Taiwan producers farm mainly the malabar grouper, potato grouper, brown-marbled grouper, giant grouper, orange-spotted grouper and leopard coral trout. According to the Pingtung Aquaculture Association, 90% are exported to Hong Kong, China (mainly the coastal provinces of Guangdong and Fujian), Japan, South Korea and Southeast Asia. Under the landmark cross-Taiwan Strait trade pact, Economic Co-operation Framework Agreement (ECFA), the 13% tariff for grouper imports into China was eliminated in mid 2010.

Although Taiwan produces only 21% (17,042 tonnes) of the global farmed grouper production (75,669 tonnes) in 2008 (Fishstat Plus, 2010), in terms of value, the production comprises 52% of the world's total value since groupers are sold live at higher prices. Taiwan faces competition from Indonesia, Thailand, Malaysia and in particular south China where production has been increasing. However,

Taiwanese producers say that they have an edge, particularly in some species. Malaysian producers can farm the giant grouper, *Epinephelus lanceolatus* but Taiwanese producers still hold the key to its breeding. Chinese producers may have the skill to culture orange spotted grouper, *E. coioides* but not the technology to produce the giant grouper.

Grouper production is mainly in ponds and these are mainly located in Tainan County, Tainan City, Kaohsiung County and Pingtung County. As demand increased, culture expanded to cages in Penghu, across the Taiwan Straits in 1975. The common constraints in production are diseases, such as viral nervous necrosis (VNN) and iridovirus; but in 2009 and 2010, this was compounded by the damage from Typhoon Morakot and floods, respectively. The losses from farms in southern Taiwan amounted to NTD 4 billion (USD125.6 million). Initially farmers were reluctant to repair ponds but with the opportunity of marketing to China, attention is on rebuilding.



Giant grouper farming in Vietnam. Picture by Jeff Jie Cheng Chuang, Uni-President.

## Grouper fish vaccine

In January, it was announced that Taiwan scientists have successfully developed a vaccine against grouper fish iridovirus. They said that vaccinated grouper fry showed improvements in survival from 30% to 70%. Iridovirus infects at least 17 species of farm fish, including sea bream, bass and red snapper. The new vaccine, developed by Council of Agriculture (COA)'s Animal Health Research Institute, can be used on popular breeds such as banded grouper and giant grouper. Relevant government agencies are expected to approve mass production of the vaccine by the end of 2011.

"With this vaccination at hand, the annual turnover of Taiwan's grouper aquaculture industry can increase from the current NTD 3.8 billion (USD127.5 million) to NTD 8.8 billion (USD 295 million)," said COA Minister Chen Wu-hsiung in the United Daily News.

## Indoor culture of groupers

In February, the National Kaohsiung Marine University's Advanced Aqua-Bio System Lab announced through a video on [www.cts.com.tw](http://www.cts.com.tw), their breakthrough in culturing groupers indoors. This is called the 'drawer breeding' technology where fish are kept in shallow water. This was developed in line with the university's campaign to protect marine farms from natural catastrophes. This came at an appropriate time as cleaning up ponds ravaged after the typhoon and floods, is a massive and expensive operation. In Taiwan Today, the team also said that amid the threats of disease and climate change, using such farming technology will ensure the future viability of the aquaculture industry. They said that using the technique not only reduces viruses in the fish but also boosts the fish's resistance to disease, allowing for greater production efficiency. Survival is higher as the controlled temperature at 22 to 28°C reduces the vulnerability to diseases.

# Two shrimp vaccines

An Iowa State University-based shrimp research has led to an international licensing and marketing agreement for two vaccines to be used in shrimp farming around the world.

Hank Harris, professor in animal science, started working on shrimp vaccines in 2000 and has now reached an agreement with one of Asia's dominant aquaculture producers for collaborative research support and marketing of the products resulting from the research in Asia and major shrimp-producing countries in the Americas. The two most devastating are white spot syndrome virus (WSSV) and infectious myonecrosis virus (IMNV). Both are being targeted by this vaccine development program. Harris has worked for 30 years developing swine vaccines, and recently developed a vaccine to prevent pigs from getting the H1N1 virus.

The research has led to effective vaccines, but the current challenge is how to vaccinate individual animals. Harris said, "Right now, we're looking at delivering the vaccine orally in the feed through a pellet they would eat, or immersing the post larvae in (the vaccine) in the water."

With the help of the new agreement, Harris thinks he will have figured out a delivery method and will have an economically viable vaccine for use in commercial production within six months to a year.

# Major marketing campaign for cobia

**Marine Farms Vietnam, in collaboration with Nordic Group, will launch a major public relations campaign in the coming months to promote farm-raised cobia to restaurants, grocery stores, caterers and consumers in the US.**

The sashimi-grade fish has been test marketed and received high marks for its versatility and flavour by restaurant groups nationwide. The public relations program will include social media, a new website, cooking demonstration videos, recipes developed by professional chefs, direct marketing, presentations, media relations and promotional materials for customers.

"We firmly believe that it is finally time for cobia to live up to its promise as the 'next sensation in the seafood industry,'" said Terje Korsnes, CEO of Nordic Group ([www.nordicgroupUSA.com](http://www.nordicgroupUSA.com)). "We have gone through the quiet phase of product development. It is now time to raise the product profile and create awareness at every level of the trade."

Carlos Massad, managing director of Marine Farms Vietnam, calls cobia "the ideal aquaculture fish. It compares in taste and has many of the same characteristics as Chilean sea bass and hamachi, grows to 12 lbs (6kg) in just 12 months, has more omega-3 oils than salmon and is priced competitively.

"Importantly, Marine Farms Vietnam cobia, farm raised in open sea cages at low population densities, targets the demand for a sustainable and stable supply of high quality white meat fish fillet."

The Norwegian parent company, Marine Farms A/S, has invested more than USD10 million in developing the world's largest cobia fish farming operation, utilising proven Norwegian aquaculture techniques. The fish are fed feeds with the same nutritional profile as farm-raised salmon,



*Cobia fillet and sashimi. Pictures from Marine Farms*

but without pigment additives. All fish feed ingredients are derived from certified sustainable fisheries. Marine Farms Vietnam processes the cobia in a purpose built, Japanese owned facility to certified sashimi grade specifications. The fish is frozen and vacuumed packed as long loins and skinless/boneless fillets. Food professionals recognize Japanese sashimi grade as the highest standard of quality in fish.

Nordic Group is the exclusive marketing agent for Marine Farms Vietnam in the United States and Canada. The fish will be sold under the akvacobia brand ([www.akvacobia.com](http://www.akvacobia.com)).

## New source of protein can replace fishmeal in a variety of farmed fish species

**A third party study by the Aquaculture Research Institute at the University of Idaho has found that PetroAlgae protein concentrate (PPC) can replace menhaden fishmeal protein at levels up to 100% in feeds for tilapia. The study also found that PPC would be suitable as a fishmeal replacement for other farmed fish species.**

"We are very encouraged by the results of this extensive study because they point to PPC as a highly desirable replacement for fishmeal at a time when feed demand is expected to increase dramatically in the face of limited traditional supply," said Dr. Ronald W. Hardy who heads the Aquaculture Research Institute and directed the nine-week comprehensive study.

PPC is produced as a co-product along with the renewable fuel feedstock by the micro-crop technology system of PetroAlgae Inc. The company ([www.petroalgae.com](http://www.petroalgae.com)), based in Melbourne, Florida, USA is a renewable energy company that licenses and deploys the leading biomass production platforms. The company's technology enables the growing and harvesting of a wide variety of non-algae, aquatic micro-crops suitable to local climates in open-pond bioreactors. Micro-crop farms utilising PetroAlgae's technology are highly productive and grow new sources of protein locally that are not genetically modified and are resistant to local diseases.

The study concluded that PPC is capable of replacing fishmeal protein up to 100% in feeds for tilapia, without the need for amino acid supplementation or other adjustments to the formulation, and can provide growth performance similar to fishmeal. When combined with fishmeal, it supported higher fish weight gain than with fishmeal alone, suggesting a positive synergistic effect most likely related to favourable amino acid balance in the feed. PPC does not change the composition of tilapia, nor does it increase tilapia mortality rates. Together, these findings indicate that this is a safe feed ingredient with no toxic effects after nine weeks of feeding.

The Latin America fish meal industry is far from Chinese and European consumption centres and the International Fishmeal and Fish Oil Association (IFFO) has estimated that each tonne of fishmeal travels an average of 5,000km to reach its end-user in the aquaculture industry. In contrast, the micro-crop farms using PPC can be sited locally, close to consumption centers. Therefore, PPC has the ability to reduce the industry's carbon footprint.

# News in Brief

## Friend of the Sea certification for shrimp from India

Sharat Industries Limited is a pioneer in the culture of *Litopenaeus vannamei* and the Friend of the Sea certification is evidence of its sustainable farming practices, said S. Prasad Reddy, the managing director. The culture area is in Thotapalli Gudur Mandalam, Nellore District and covers 180ha. The brood stock is imported from Oceanic Institute (OI) in Hawaii. In India, the Coastal Aquaculture Authority (CAA) supervises the supply of specific pathogen free (SPF) brood stock for hatcheries under the regulations of the Livestock Importation Act, 2001 and culture of the shrimp under the central government guidelines. The press release by Friend of the Sea ([www.friendofthesea.org](http://www.friendofthesea.org)) reported the farm has bio security measures such as bird control and crab fencing in place along with the use of probiotics and a closed system of water management. Since 1994, Sharat Industries has an integrated project with a shrimp hatchery, grow-out farm, feed mill and processing facilities. In 2004, it was the first company in India to start farming vannamei shrimp. The company produces fresh, frozen and cooked vannamei shrimp.

## China takes US to WTO on shrimp

China has launched a litigation proceeding under the World Trade Organisation (WTO) against the US requesting the removal of the 'zeroing' method of calculating anti-dumping duties on its warmwater shrimp. Zeroing is whereby the domestic price of a certain product is compared with its import price to the US and then adjusted to account for transportation and handling costs. The US has reduced its use of zeroing in response to repeated WTO rulings and in December 2010 has proposed to end this in annual reviews of anti-dumping duties.

In 2010, the duties were reduced to the range of 5.07% - 8.45%, following an appeal to the US International Trade Commission (ITC). The Ministry of Commerce said that Chinese exports of shrimp to the US have been affected by the high tariffs since early 2005 when the tariffs ranged from 27.89% to 82.28%. In 2004, exports of Chinese warmwater shrimp to the US were worth USD 380 million. After the imposition of higher duties, shrimp exporters in Liaoning, Fujian, and Guangdong provinces reported declines in exports (China Daily News). The US first imposed anti-dumping duties on shrimp from China, Brazil, India, Thailand and Vietnam in 2005 and has been considering the larger question of whether to extend them for another five years.

## Genomar shows losses in Q4 2010

Norwegian group Genomar has reported losses in the last quarter of 2010. Revenues were NOK 9.89 million (EUR 1.3 million) in the fourth quarter of last year compared to NOK 4.36 million (EUR 565,042) in the corresponding quarter of 2009. The company experienced a negative EBITDA at NOK 18.74 million (EUR 2.4 million) against NOK 5.37 million (EUR 694,879) in Q4 of the year prior. The Board of Directors has set up a strategy to cut costs in 2011.

The report explained that higher mortality of tilapia in Trapia, Malaysia during October occurred with regards to harvesting, logistics and transportation of the fish to the factory. Losses were also attributed

to lower volumes than expected which led to high unit costs. Exporting fillets started in Q1 of 2010 and the company took over the processing plant in May 2010. In the grow-out phase, the outcome of the tilapia tested with inoculation of a prototype vaccine has yielded positive results with lower FCR and higher fish quality. Direct harvesting has produced good survival rates. In 2011, the company will increase production with 60 cages. It is also looking for a more stable work force, costs cutting in feeds, better harvest and logistics and to streamline export sales in local and regional markets. In China, the Genomar Supreme Hatchery in Hainan was hit by the worst flood in 50 years. However, hatchery operations have resumed, ready to meet demand in 2011. Markets in 2011 are expected to be better than in 2010.

## SBT fingerlings have reached 34 days

Clean Seas, Australia has succeeded to grow southern blue fin fingerlings (SBT) to 34 days. These are expected to go into sea cages in about three weeks, if all continues to go well with its world-leading attempt to commercially breed the species, according to a report in [Adelaidenow.com.au](http://Adelaidenow.com.au). Spawning started on January 20 and has continued on and off since then with the oldest fingerlings already transferred to nursery tanks. Clean Seas managing director Clifford Ashby said the aim is to transfer them to the sea in mid-March. "In the event of unsuitable sea conditions and or temperatures, the company also has the option of continuing the grow-out phase in the new land-based Arno Bay nursery tank facility. The fingerlings are eating kingfish larvae and are soon to be weaned onto man-made feeds."

## First Danish fishmeal order for China

Danish company, TripleNine has succeeded in securing its first fishmeal order for China since 2001. In December 2010, it was approved to export fishmeal and fish oil to China. Business Development Manager Yanqi Zhang Larsen said that they have already managed to sell a major consignment of fishmeal to a Chinese customer. It is the first time since 2001 that a Danish fishmeal factory has sold fishmeal to China (triple 999 newsletter).

## Lower AD duties for Vietnamese and Indian shrimp

In March, the US Department of Commerce (DOC) announced the final results of its review of anti-dumping (AD) duties on Vietnamese frozen shrimp from February 1, 2009 to March 31, 2010. Duties applied to all Vietnamese exporters for the 2008-2009 periods have been reduced from those announced by the DOC at the end of September 2009. This means that three exporters enjoy a low rate of 0-1.67%, 29 others had their duties reduced from 3.92 to 1.52% but the average tax for the remaining exporters is still very high at 25.76%. The preliminary results for the fifth administrative review of the anti-dumping duty on shrimp exported from India announced by the DOC, reduced the average duty to 1.69% from 2.67%. Falcon Marine Exports Limited and Apex Exports, the two mandatory respondents of the review, will attract a duty of 1.36% and 2.31% respectively. In the business standard.com, the Indian seafood export sector was actually hoping for below 0.5% (zero duty) as the duty was being reduced in each round of the review.

# A NEW GENERATION OF ARTEMIA CYSTS

**SEP** Art  
TECHNOLOGY

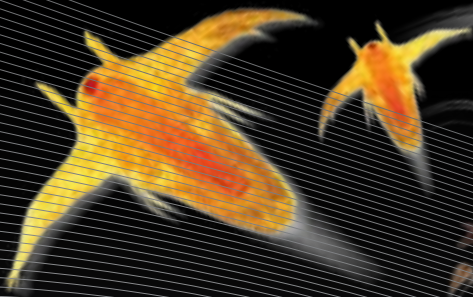

- Complete separation
- Clean biomass
- Undamaged nauplii
- Increased biomass output



[www.inve.com](http://www.inve.com)





## Opinion article

# Effective feeding in shrimp culture

The farmer should be in control as this is the highest cost component. It can be highly influenced by the use of auto demand feeders and changing climatic and culture conditions, says Soraphat Panakorn.

*A well broadcasted feed will result in effective FCR and better water quality*

Feed cost in any shrimp culture operation amounts to around 50% of the total operational cost. Although this has decreased from the quoted proportions of 70% during the early days in commercial shrimp culture, it still requires proactive management. Feeds cause over 60% of problems in the shrimp ponds through the accumulation of organic wastes. Each 100 kg of feed input will leave around 70kg of waste, if the feed conversion ratio (FCR) is 1:1. The side effects of uneaten feed collected on the pond bottom, are toxic gases when oxygen is low or when there is an algal bloom (chart 1). This article focuses on effective management in feeding.



## Overfeeding vs under feeding

Overfeeding can accelerate growth during the early development stages especially when water quality is still good. However, when the pond system is overtaxed, we will have the situation when organic waste accumulates over the carrying capacity of the pond. This is when FCR is high due to lower yields. Thus, it is always prudent to practise under feeding even though the ADG (average daily growth) is low. The best solution is feeding on demand, which requires skill. The benefits are healthy shrimp and less stress for the farmer!

*“Demand feeding, takes into consideration shrimp behaviour. Most of the mistakes we make are from thinking in the human way and not as a shrimp.”*

## Understanding feed

A good shrimp feed is characterised by the following;

- Similar in size, shape and colour
- Sharp pellet cuts
- Low dust
- Fine skin
- Strong and attractive smell
- Water stability around 3 hrs
- Absolutely, no contamination such as sand, glass, raw material, fungi, humidity etc.
- Feed must be attractive and palatable

*“In general, we can regard the feed as an asset before it is distributed into the water and as a liability after three hours in the pond.”*



# WHO CARES?

Who cares that one extra fish, one extra shrimp, or improved survivability, will make the difference between profit and loss in the aquaculture world this year?

Alltech does!

In fact, so do the 2,300 people worldwide, committed to producing and managing the Alltech range of patented, high quality, safe and natural ingredients that improve feed quality, animal health, food safety and industry profitability.

Supported by 30 years of research, 150 PhD theses, 70 masters' theses and over 300 reviewed papers, Alltech ingredients are proven to promote animal health and performance through better nutrition ...*naturally*

So the next time you ask the question, who cares? Remember at Alltech...

# WE DO!



**Nutrition, health, performance ...*naturally***

For more information on Alltech Aqua Solutions, email: [aquasolutions@alltech.com](mailto:aquasolutions@alltech.com)  
or contact your local Alltech representative.

[www.alltech.com](http://www.alltech.com)

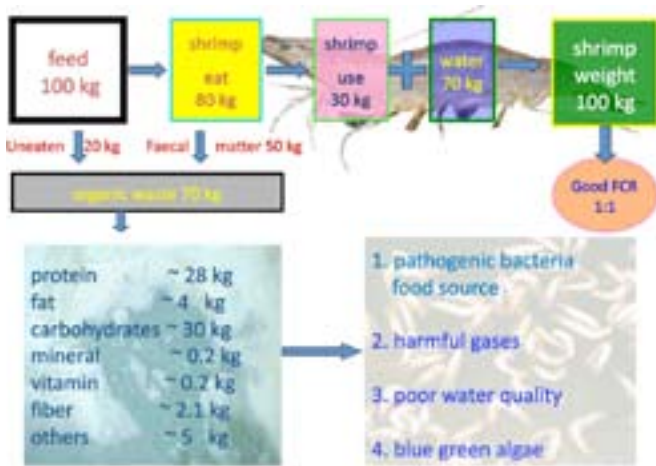

Graphic on waste output in a shrimp pond and the consequential problems

We should depend on the feeder, whether manual or automatic, to present the feed when the shrimp is ready to eat and to avoid accumulation of uneaten feed.

### Understanding the shrimp

Both black tiger and white shrimp have the hunting behaviour of a carnivorous crustacean. It uses sensory and chemical senses to find feed and needs minerals to grow and a suitable pH for blood circulation and digestion. The environment affects the body system including appetite, metabolism, molting, digestion and the immune system. Molting is a prerequisite to growth and during this stage, adaptation to the environment is important. Feeding shrimp must take into consideration its very short gut, and the shrimp's active movements and aggressive behaviour. In feeding shrimp, it is important to understand all these characteristics of the shrimp.

### Environment and feeding

There are several water parameters which have an impact on feeding. The two main ones are dissolved oxygen and temperature. Shrimp appetite decreases when dissolved oxygen is less than 4 ppm and it stops feeding when this is less than 2 ppm. The optimum water temperature is 28-30°C. For every 2°C decline in temperature, the feed volume should be reduced by 30% from the average feed volume. Prior to broadcasting feed, it is wise to check water temperature. If a dissolved oxygen meter and temperature probe is not available, the acceptable time to feed is when the sun is shining on the ponds for at least one hour before the first feed. The dissolved oxygen will be ideal at this time.

### Impact of high temperatures

The period the feed stays in the gut will vary with water temperature. When it is hotter, shrimp will eat faster and will also excrete faster

### Observations of feed trays



When this is lifted up, observations will give data for feed adjustments based on current culture situations. In a. with shrimp in the tray, the feed amount is maintained. In b. with left over feed, the amount should be decreased for the next meal and in c. without shrimp, feed is increased by 5%.

in comparison to at lower temperatures. The farmer should be able to strictly control the feed amount by following the 'feeding chart' in summer, whilst providing for a wider gap between meals during colder periods.

### Water current flow

As the shrimp moves against the water current, the feeder must scatter feed following the flow of the current. Shrimp will move along the feeding area together as a large school. The feeder should spread the feed thinly and evenly. It is advisable that the feeder should not drop a large amount of feed in a small area. This is the cause of large size variation in the shrimp. Good feeding will result in a better FCR and good water quality at the same time.

### Feeding area

In Thailand, farmers use water currents to keep sludge in the middle of the pond only. As the feeding area should be free of any sludge or harmful gases, the farmer will mark the area with a bamboo stick. When tea seed cake is applied to eradicate fish, the fine bubbles show water movement. Feeding should be avoided in the area where water is stagnant.

### Feed tray

When there is no feed left in the tray, it does not necessarily mean that the shrimp is eating well. It could also be an indicator that 'something may be wrong'. This requires an investigation. Actual feeding is not even, it fluctuates depending on the situation (see below).

### Aeration and feeding

During the first month of culture, it is advisable to stop aeration during feeding. However, after a month of culture, aeration should continue during feed broadcasting, especially in the case of clear or turbid water or on a cloudy day. The dissolved oxygen will be from two main sources: aeration and phytoplankton. However, without oxygen from phytoplankton, a 30-minute stoppage of aeration can weaken shrimp and lead to mortality.

When this happens, it is recommended that the farmer drops one feed tray containing feed mixed with minerals and vitamins at the edge of the sludge area. This is to examine the weaker shrimp and also to aid recovery. This is also called the 'ICU room for shrimp'. Weak shrimp will avoid the strong and healthy ones by staying in a non competitive area which happens to be the sludge area.

### Growth rate and feeding

Limiting feeding or skipping designated meals will not affect growth rate but will help with water quality. In Thailand, many farmers implement 3 ½ meals per day. They feed only 30-50% of the average amount for the last meal at night as shrimp die through over feeding, not through hunger. Nevertheless, it is the farmer who should be



Bubbles with teaseed cake application show the moving and stagnant water areas.

**Table 1. Some situations when the farmer must closely monitor feeding.**

Situation	% of recommended feed
Rain during meal times	50% or wait until rain over
Heavy bloom	70% for 3 days or until bloom decreases
Molting (average pH 8-9)	30% afternoon, 50% night, 110% morning
Molting (average pH<8)	80-90%
Windy	60%
Plankton drop	50% until it clears with oxygenation and microorganism.
Water exchange (less in amount or parameter differentiation)	80% for 2 meals.
Water exchange (large variation)	50% for one day.
Apply some chemical	0% for one meal
DO <sub>2</sub> shortage and shrimp surfacing in the morning	0% for one day
Presence of toxic gases	60-70% until toxic gases are reduced by half.
Strong climate changes	70-80% until climate stabilises
22 or 35°C	Wait until water temperatures decline to feed.

proactive and vigilant. They should investigate and determine the circumstances and adjust feed accordingly before shrimp itself loses appetite and uneaten feed pollutes the pond system.

### Using the feeding chart

Several years ago, we used to calculate feed amount by examining the feed tray. However, recently from a systematic data collection and analyses using statistical methods, we have derived a 'feed guideline chart'. However, adjusting feed by feed tray is still necessary whereas the maximum amount should be determined using the feeding chart.

The feeding chart gives the amount per 100,000 shrimp. It gives an overview of the feed demand and guidelines such as growth rate etc. Most Thai farmers take this as maximum amount or 'ceiling amount' of feed to supply to shrimp. This works well if conditions are ideal, i.e.



Rising feed cost

Escalating fish meal price

Opportunistic diseases

Environmental impact

Low Shrimp & fish prices

## Tired of hearing only bad news?

*Feed is the main cost in most aquaculture operations ...*

*and the most difficult one to reduce when ingredient prices are rising ...*

**AQUAGEST®** *maximizes digestibility and feed utilization efficiency*

**AQUABITE®** *enhances palatability and appetite*

**SANACORE® GM** *improves growth and productivity by promoting a healthy gut microflora*



Visit us at World Aquaculture Conference & Exhibition  
Natal, Brazil • June 6-10, 2011

Booth # 208

*applying nature for a healthy and sustainable future*

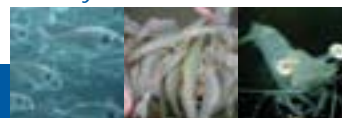

info.aqua@nutriad.net  
www.nutriad.net

## Sample of feed chart for specific location, season, density, culture technique and feed quality\*

Feeding program for 125 post larvae (PL/m <sup>2</sup> ) for 3 partial harvests								
days of culture (DOC)	weight/count	%feed/ body weight/day	feed sizes in mm, range in width x length	ADG	FCR	Feed (kg) per 100,000 PL/day	feed in tray (g/kg of feed)	checking time (hr)
1-10	0.5/2000	~20-15	0.5-0.7x0.8-1.5	0.05		2.0		
10-20	1.5/667	15-8	0.8-1.0x1.0-2.0	0.10		3.5	2.0	3.00
20-30	2.5/400	8-6.5		0.10		9.0	2.0	3.00
30-40	3.5/286	6.5-5	0.8-1.0x1.0-2.0 + 1.5-2.0x1.5-2.5	0.10	0.50	15.0	2.0	3.00
40-50	5.5/182	5-4	1.5-2.0x1.5-2.5 + 1.2x2-3	0.20	0.80	20.0	3.0	2.50
50-60	7.5/133	4-3.5	1.2x2-3	0.20	1.00	30.0	3.0	2.50
60-70	10.0/100	3.5-3.33	1.2x2-3 + 1.5x3-4	0.25	1.10	40.0	4.0	2.15
70-80	12.5/80	3.33-3.06	1.5x3-4	0.25	1.20	45.0	4.0	2.15
80-90**	15.0/67	3.06-2.88	1.5x3-4+2.2x5-6	0.25	1.30	40.0	5.0	2.00
90-100	17.5/57	2.88-2.68		0.20	1.40	40.0	5.0	2.00
100-110	19.5/51	2.68-2.46	2.2x5-6	0.20	1.50	40.0	6.0	2.00
110-120	29.5/47	2.46-2.30	2.2x5-6+ 2.4x5-6	0.20	1.60	35.0	6.0	1.45
120-130	23.0/43	2.30-2.10		0.15	1.70	35.0	7.0	1.45
130-140	24.5/41	2.10-2.0	2.4x5-6	0.15	1.80	35.0	7.0	1.30
140-150	26.0/38	<2.0		0.15	1.90	35.0	8.0	1.30

\* This was developed with a farmer over a three year period  
 \*\*from DOC 80 days, feed amounts should be reduced to control water quality



**Choose the Best for You**

we are able to provide you with quality products at competitive prices.

**Supply**

- Fish Feed
- Shrimp Feed
- Wheat flour
- Vital Wheat Gluten
- Corn Gluten Meal



**Fairway (Thailand) Co., Ltd.**  
 14 th Floor Bangnathani, Building 1/28 Bangna-Trad Rd.,  
 Bangna, Bangkok 10260 Thailand  
 Tel : 02-398-5918 Auto 7 Lines Fax : 02-398-5919  
 Email : fwt@fairway-thailand.com www.fairway-thailand.com

the feeder knows the exact number of animals and whether the feeding area is clean, there is adequate oxygen with enough aeration or good water current. Consequently, most Thai farmers adjust their feed based on the feed chart but will still check feeding patterns by using the feed trays.

Some farmers also develop their own 'feed chart' which is suitable for their own farming conditions, soil types, water parameters, climate, seed source etc. Generally, I recommend the feed amount to be reduced to 80-90% of that in the feed chart. By using this chart, the farmer can calculate for ADG, biomass, survival rate and other attributes. It is also recommended that at least one staff in each farm should know how to utilise this information to monitor shrimp feed together with feed tray observation.

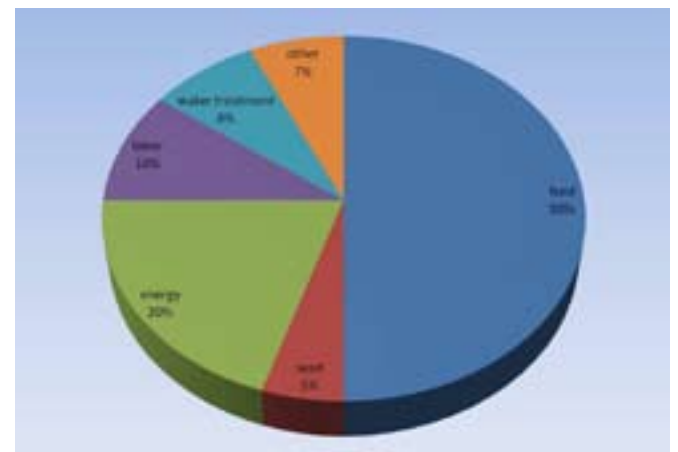

Summary of production costs in a shrimp culture operation



Ideally, the feed tray should have a 5 cm tray leg

### Using the feed tray for feed adjustment

Base on the hypothesis that a feed tray is placed in the most conducive place in the feeding area, the farmer will drop a large amount of feed to attract shrimp. Common knowledge is that if the shrimp can finish feeding within a specific time, feed amount has to be increased or the status quo maintained.

However, the examples below show that sometimes mistakes happen when feed trays are not managed optimally, and results will be erroneous.

- Fake tray results tend to occur when sludge spreads to feeding area. Shrimp tend to finish the feed in the feed tray before moving on to seek feed pellets in the sludge area.
- Wrong feed tray position: with low or high water current, feed can be displaced with the water.
- A quick dropping or lifting of the tray can displace feed.
- Leftover feed: increase in pollution will result in higher risk of mortality.

### Guidelines for feed trays

The proper position should be in flat areas, i.e on the pond floor with mild water current. The feed tray should fall freely. The water current

should only lift the angle of the feed tray by around 15 degree from the perpendicular direction. The tray size should be around 0.4-0.6 m<sup>2</sup> with an 8-10 cm depth. Ideally, one should have a 5 cm tray leg (see photo). Trays for the vannamei shrimp should not be clean as the shrimp likes dirty trays, in contrast to monodon shrimp. The tray should be dropped or lifted gently and under strong sunlight; it is preferable not to lift above the water surface.

### Key factors

The feed tray will indicate the following. If there is leftover feed, the amount for the next meal should be reduced by 10% provided that weather and other conditions remain the same. If the feed tray is clear of feed with some shrimp in it, the feed amount should be maintained. If the feed tray is clear of feed with few or no shrimp, then the amount for the next meal should be increased by 5%, again if weather and other conditions remain the same.

It has been calculated that the maximum feed amount of 42kg/per 100,000 shrimp will be reached when shrimp size is around 80-100 count. This is for manual feeding and in the case of demand feeding, 35kg/100,000 shrimp at 80-100 count is the maximum limit. After 80 count onwards, the feed should be maintained at this amount. Feed should be reduced by 5% when shrimp pass the 50 count level. Key indicators for overfeeding are algae bloom or the rise in ammonia levels. When this occurs, the most effective solution is feed reduction.



**Soraphat Panakorn** is Technical Sales & Support Manager, Novozymes Biological Aqua Business unit, Asia Pacific Region. His message in this article is that farmers should use feeds effectively and not let this destabilise their culture business. He welcomes feedback from readers.

Email: [janeary161975@hotmail.com](mailto:janeary161975@hotmail.com)

You asked for a **DO METER**  
that's **SIMPLE** and **RUGGED**.  
Here it is.

**YSI AQUACULTURE**  
PROVEN. TRUSTED.

The **NEW YSI Pro20** is an easy-to-use handheld dissolved oxygen instrument with the fastest response times available. Lower your total cost of ownership with user-replaceable sensors and cables.

**Get what you ask for with YSI. 800 897 4151 US +1 937 767 7241**

**WE KNOW**  
**YSI** **D.O.**  
[YSI.com/pro20](http://YSI.com/pro20)

# New developments in extrusion

By Mian N. Riaz

**For any industry to achieve sales, it has to add value to existing products, satisfy customers and maintain an employment base, critical to develop and innovate new equipment. This is also true for extrusion technology used to process aquatic feed.**

Recently, the main trends in the aquatic feed industry are:

- Food safety: Challenges with contaminated ingredients and products
- Raw material costs: Volatile ingredient markets
- Market conditions: Current economic recession is impacting consumer buying habits
- Energy and water conservation: Higher energy costs and concerns on water availability
- Emissions control: Reducing odour and particulate emissions
- Supply chain cost reductions: Shipping costs are higher
- Automation: Reduces labour costs and assists in food safety
- Labour costs: Uncertainties in the labour pool
- Flexibility: Ability to react quickly to new market directions
- Lean manufacturing: Cost cutting and improving efficiencies

To achieve the above trends, the extrusion industry has developed and improved some of the processing tools in the manufacture of aqua feed. In this article, I will discuss several of these improvements and focus on some specific designs.

## Improvement in preconditioning

The preconditioner plays a very important role in processing feed via the extrusion process. In 1948, the first single shaft preconditioner was developed. Double conditioning cylinder came in the market in 1968, but it was still not providing enough retention time. In 1988, differential diameter conditioner (DDC preconditioner) was the new innovation which could provide mixing as well as retention time.

In 2008, the extrusion industry introduced the new high intensity preconditioner, which can provide, mixing, retention time as well as proper sanitation.

### What is the high intensity preconditioner?

This has the following features;

- Mixing intensity controlled by speed and rotational direction of each shaft (individual VFD drives)
- Increased shaft speed increases radial and distributive mixing
- Up to 3 times more beater contacts than the original DDC
- Instant display of retention time
- Retention time can be varied



*New single screw extruder with high intensity preconditioner*

High intensity preconditioner provides several benefits for aqua feed manufacturers. These include improved product hygiene; higher levels of liquids and slurries (increase mixing), reduced product waste at startup/shutdown and 'Flush' and CIP modes.

### Industry requirements for equipment design and construction

In general, the industry requires equipment which can minimize fugitive dust and product buildup and accumulation and easy access for inspection and cleaning. It also requires equipment designed to minimize leakage/spillage and exhaust streams and systems to contain/capture and recycle under-processed material.

### High intensity preconditioner (HIP) improves pasteurisation and sanitation

- Increased mixing gives a more uniform product moisture and temperature



*New thermal twin screw extruder*

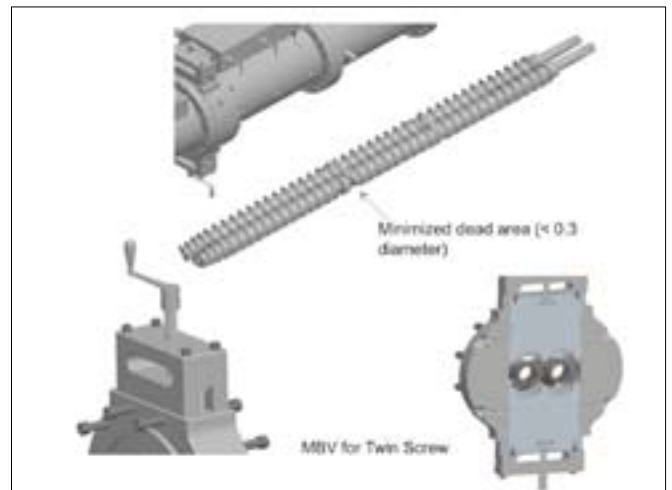

*MBV for twin screw*



Back pressure valve in different position during extrusion

- Slide gate reduces discharge of under-processed material
- Slide gate becomes integral part of sanitation process
- Designed to reduce waste (under-processed product)
- Easy access for inspection and cleaning
- Designed to minimize leakage/spillage and exhaust streams

### Improvements in single screw design

Currently, new single screw extruders are available with all stainless steel construction with no seams. These extruders have minimum surfaces for product accumulation. Designs of these extruders are such that cleaning is very easy.

Now single screw rotating elements offer the following benefits:

- Accurate screws for more positive conveying
  - Radius at root diameter to prevent product buildup
  - Creates low pressure zones in inlet and steam injection sections

- Positive conveyance to shallow flight screws and dies
- Shallow flight screw elements available at discharge end
- Extended wear metallurgy
- Involute splined shaft

### Improvements in thermal twin screw design

It takes a certain level of energy to create a given product via extrusion. Thermal and mechanical energy are the major sources of energy in the extrusion process. There are several effects which take place when we change the ratio of mechanical to thermal energy in extrusion system.

These effects include;

- Influences product characteristics
- Determines utility costs/tonne
- Impacts wear costs/ton and
- Affects your “green” status.

New thermal twin screw extruders with high intensity preconditioner are available which provide several features including; 25 L/D barrel length, unique screw profile, high capacity barrel steam injection, vent and MBV (as required) and hygienic frame.

### Benefits of thermal twin screw technology

There are several benefits associated with new thermal twin screw. They use less costly energy source (vary input ratio of thermal to mechanical energy), have lower wear costs and produce less sticky products due to low shear. There is also the ability to achieve higher fresh meat and other slurry levels and the more “natural” cooking (thermal energy) leads to development of new products.

### Improvements in hardware tools

There are several hardware available to aqua feed manufacturers that can be used with the existing extruder to control the SME and product density on-line without shutting down the extruder. The most commonly

*Assuredly... innovation is our enduring legacy.*



Since 1935, we've been helping customers solve problems and capitalize on opportunities faced by their businesses.

Seventy-five years ago, a key answer was a molasses mixer. Today, the solutions tend to be more technologically complex – but our founding pledge remains unchanged.

At Wenger, we innovate to solve customer challenges.

*And then we do it again.*



*Inventing the new original since 1935.*

SABETHA, KANSAS USA 785-284-2133 INFO@WENGER.COM WWW.WENGER.COM  
 USA BELGIUM TAIWAN BRASIL CHINA TURKEY

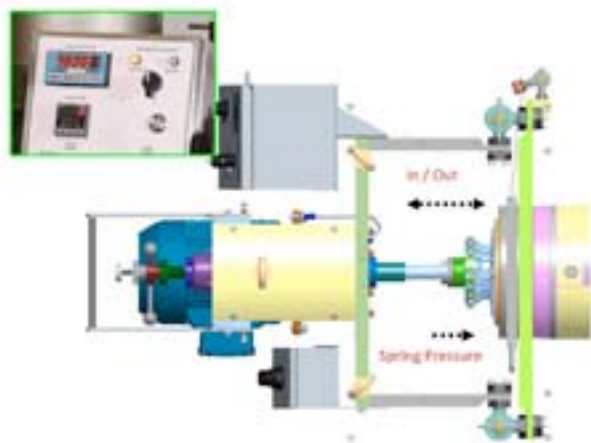

*New adjustable knife drive*

used on-line hardware is the valve internal to extruder barrel (MBV) and the valve at discharge of extruder (BPV)

**MBV (Mid Barrel Valve)**

In general MBV can control SME and product density. These are designed for twin and single screw extruders and currently they are manually controlled. In future, auto controls for SME and product density will be available.

**Features of new single screw MBV**

A new mid barrel valve offer several new features including those to vary SME and product density on-line without adjusting moisture, achieve higher SME, higher cook, lower bulk density even with fresh meat and high fat recipes and minimise the amount of dead area in screw configuration.

**BPV (Back Pressure Valve)**

Restriction valve located at discharge of extruder to adjust extrusion pressure and SME inputs does not negatively affect the output. Cook values may actually go up with BPV installed and product density (buoyancy) can be adjusted easily – fully open position may actually increase product density

**Benefits of Back Pressure Valve (BPV)**

Back pressure valve (BPV) offer several benefits such as to divert off-spec product for improved sanitation and quality control, service die/knife/conveyor without stopping extruder, on-line adjustment of SME to control product properties (cook, density, shape, water stability, oil absorption) and eliminate extruder configuration changes.

**Improvements in adjustable knife drive**

Recently, we have seen several new improvements in adjustable knife drive which includes the following:

- Knife drives are mounted to extruder



*The new hygienic pneumatic pickup hood*

- Swings away for maintenance / tooling changes
- Improved clean-ability
- Blade position and spring force can be adjusted while running
- Digital readout for blade position to monitor blade displacement and wear
- Improved blade / die life
- Safer shaft / knife design

**Improvements in hygienic pneumatic pick up from hood to dryer**

Now we have the pneumatic pick up system available with filtered (HEPA), pressurized air which maintains positive air pressure in the hood area, including during reject. They can swing open and disassembled for cleaning. Some additional new features are:

- Vertical opening
- Sample port
- Viewing windows

**Improvements in control system for extruders**

There are several improvements in extrusion control systems. The latest addition in control systems is called E-Doc (Extrusion Dryer On-Line Communication System). Continuous, on-line measurement, display, and control of the following during extrusion and drying process:

- Energy efficiency
- Production rate
- Feed safety
- Quality assessment

E-Doc system provides several benefits for extrusion operations including;

- On-line devices collect information (measure product flow, energy input, and product technical qualities);
- Data processed by mass/energy evaluation programs which is shared to extruder/dryer;
- Automation of energy and moisture control during drying process;
- Control system links extruder/dryer together as integral parts of process; and
- Provides safeguards for product quality.

A typical E-Doc system includes extruder, dryer, control system, on-line measuring device, and embedded evaluation program.

Features of a typical extrusion-dryer on-line communication system include:

- Mass flow measurements for dry feed rate (LIW), flow meters for all steam and liquid streams, flow meters for other in-feed streams (slurries) and gas flow meters for dryer
- Energy measurements include those for the temperatures of all mass flow inputs, specific heat values of mass flow inputs, power meters and air temperatures and humidity
- On-line measurements of product technical qualities for moisture, temperature, proximate analysis, bulk density and presence of adulterants, contaminants. The instrumentation includes;

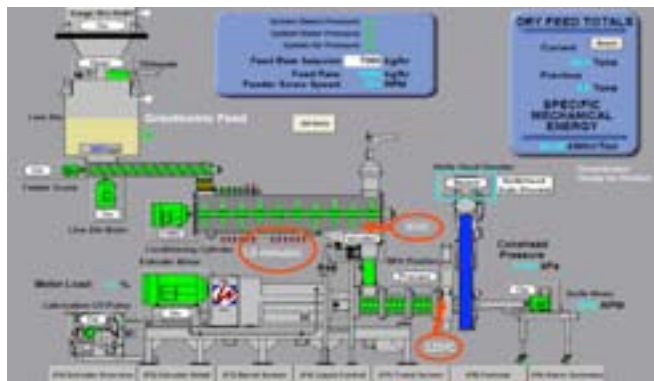

*Preconditioner and extruder temperature validation*



Bulk density system configuration

- On-line NIR analyser measures proximate analysis (protein, fat, fiber, ash, starch, etc) of dry recipe or product and presence of certain contaminants/adulterants. They are calibrated with bench top units.
- In-line microwave spectrometer measures moisture, protein, ash, and salt level of slurries
- On-line system measures product density, moisture, temperature, and image
- Mass/energy evaluation equations which;
  - Calculates specific thermal and mechanical energy inputs (kWhr/t) at any point in the process.
  - Calculates product moisture, temperature, and mass flow rate at any point in the process (example: into the dryer).
  - Calculates mass/energy balance within any selected boundary.
- Computer control/extruder/dryer
  - Feed-forward moisture control (from extruder to dryer) - either calculated or measured
  - Energy control (ASR for dryer)
  - Feed-back moisture control

**What are the potential benefits of automation of an extrusion system?**

In Process Support<sup>1</sup> via remote or live, there is process control connections in diagnostics, troubleshooting, programming and process correction and optimisation.

In the implementation of food safety practices, there is the minimisation of direct contact between production personnel and product, logging of critical process parameters and product tracking (which enables traceability).

In the optimization of energy inputs, it provides mass /energy evaluations, energy costs per unit of throughput and adjusts process to optimize energy efficiency and costs.

It is a management tool which offers real time monitoring of production floor from your office desk or PDA, data logging of the process and customized reporting formats.



Mian N. Riaz, PhD is head of the Extrusion Technology Program at Texas A&M University, College Station, USA. He conducts regular training courses on feed extrusion for the aqua and pet food industries. The 17th Annual Aqua feed Extrusion short course held in September 2010 had 37 participants from 17 countries; including participants from Thailand, Indonesia, Malaysia, Vietnam, Singapore, Australia and Pakistan. A special program for full fat soy production using extrusion technologies for South East Asia group sponsored by American Soybean Association was also conducted in 2010 with participation from Vietnam, Malaysia, Indonesia, Thailand, Singapore and Australia. Email: mriaz@tamu.edu



**ONE SHOT AT AQUAFEED PERFECTION**

**In the competitive aquafeed industry, you only get one shot to put the perfect product in the bag.** That's why so many leading aquafeed manufacturers in the industry count on Extru-Tech to engineer the perfect aquafeed production solution.

Is your aquafeed production system on target? Could you use a cost effective improvement in performance and finished product quality?

**Contact one of the Aquafeed Consultants at Extru-Tech today at 785-284-2153.**



**Corporate Office**  
 P.O. Box 8 • 100 Airport Road  
 Sabetha, KS 66534, USA  
 Phone: 785-284-2153  
 Fax: 785-284-3143  
 extru-techinc@extru-techinc.com  
 www.extru-techinc.com

# A rapid low-cost laboratory method for measuring the *in vitro* protein digestibility of feed ingredients and feeds for shrimp

By Daniel Lemos and Albert G. J. Tacon

The nutritional and economic success of a commercial shrimp feed is dependent upon the proper selection and use of high quality feed ingredients. Moreover, of the 40 or so essential nutrients contained within formulated shrimp feeds, the protein and amino acid component are generally considered as being the most important in terms of total diet cost and shrimp growth performance.

However, the protein quality or digestibility of a feed ingredient is dependent upon the composition and biological availability of the amino acids present, which in turn usually varies considerably from season to season, country to country, and the feed ingredient handling and processing method.

It follows from the above, that the determination of protein quality and digestibility is of paramount importance to the shrimp feed compounder and nutritionist. However, at present, no rapid and reliable laboratory method exists to determine the *in vitro* protein digestibility of individual feed ingredients or finished feeds. Although methods are available for determining protein digestibility within live animals (*in vivo*), these methods are laborious, time-consuming and expensive, requiring four to eight weeks to perform before apparent protein digestibility measurements can be obtained for a particular feed ingredient or finished feed.

Clearly, there is also a need for a rapid laboratory technique for use on a day to day basis for estimating protein digestibility which can be routinely used by nutritionists and feed manufacturers for ingredient selection and feed formulation.

## Rationale

The rationale behind the method is that shrimp digestive enzymes are extracted from healthy farmed shrimp and then incubated with the test feed ingredient or finished feed (Lemos, 2004), and apparent protein digestibility measured by monitoring the degree of protein hydrolysis

(DH) using a pH-stat over controlled laboratory conditions (Figure 1 and 2). The DH method has been successfully applied to assess the apparent digestibility of several different raw materials commonly used by shrimp feed manufacturers. In particular, the *in vitro* DH method has shown a high correlation with results obtained from conventional *in vivo* digestibility trials using live shrimp (*in vivo*), thus demonstrating that the method is capable to accurately predicting the apparent protein digestibility of either feed ingredients or finished feeds (Figure 3 and 4).

## The method

The DH is a quantitative indicator of the relative amount of protein digested by shrimp enzymes in relation to total protein fraction in a feedstuff, in a definite assay protocol. It is determined in a pH controlled reaction (pH-stat) between the feed protein fraction and the enzyme extracted from shrimp, precisely monitored using an automated potentiometric titrator.

The principle of analysis is based on the slight pH changes produced by enzyme activity during protein digestion. As digestion involves the breakdown of protein complexes into smaller size fractions, the digestive enzyme operates by cutting through peptide bonds that maintain protein structure. At pH levels consistent with shrimp hepatopancreas, protein breakage results in slight pH changes that can be monitored by the pH titrator with automatic correction to maintain constant pH levels by addition of NaOH.

Figure 1. Steps for the *in vitro* determination of DH (degree of protein hydrolysis) of feedstuffs for farmed shrimp: hepatopancreas sampling, enzyme extract recovery and digestion assay.

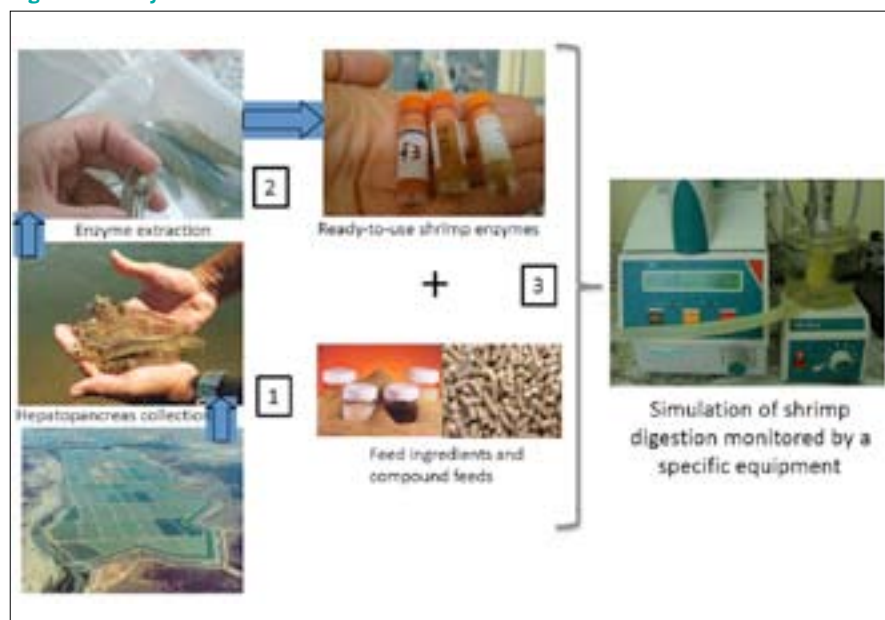
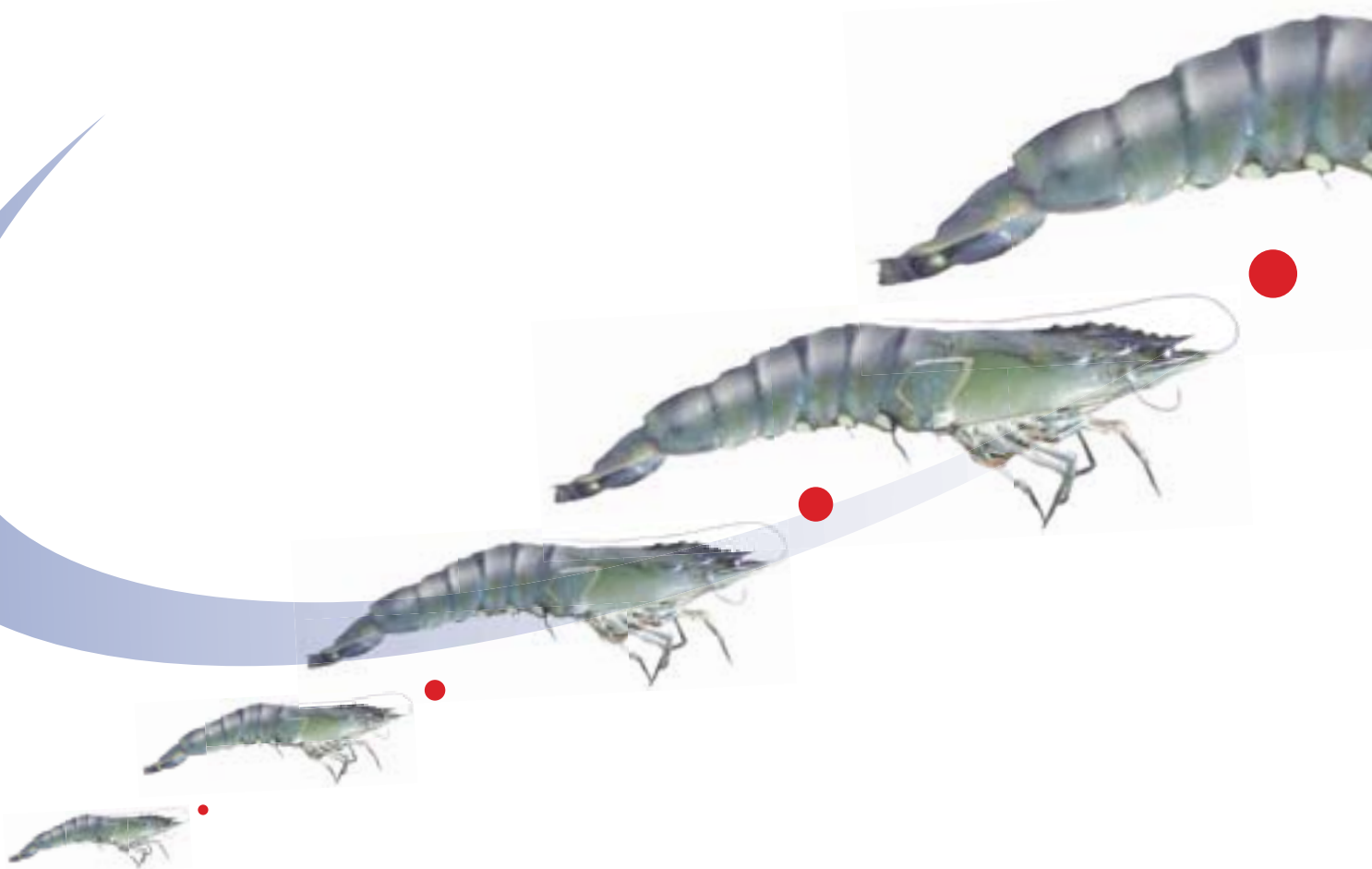

Figure 2. Automatic titrator precisely monitors feed protein digestion by species-specific shrimp enzymes.



# GROWING IS BEAUTIFUL



Our hydrolysates have a unique concentration of Natural Active Nutrients™. Thanks to their biological action on fish and shrimp growth mechanisms, they boost your feed performance and help you substitute fish meal.

Figure 3. Correlation between protein digestibility in live shrimp and *in vitro* DH values with shrimp enzymes using 26 different feed ingredients for juvenile shrimp *L. vannamei*.

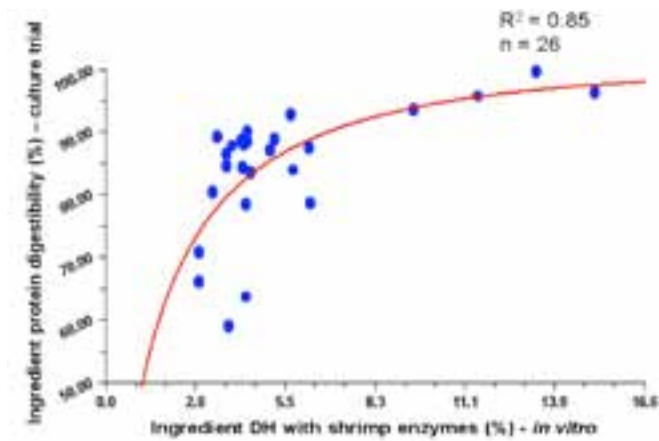

At the end of the assay, the quantity of NaOH expended in neutralising the pH of the feedstuff + enzyme reaction mixture is proportional to the DH of the ingredient or feed. Moreover, if so required, all the analytical routine including sample preparation may be controlled and registered by specific computer software.

Previous research data have shown differences in digestion output according to the species so that shrimp digestive enzymes may act distinct from different fish or terrestrial animal species. It follows therefore, that species specific enzymes must be used for measuring protein digestibility for the target species.

In the DH method, shrimp digestive proteases are obtained from the hepatopancreas excised from healthy animals under commercial farming conditions. Moreover, the age of the shrimp sampled for enzyme extraction should correspond (as far as possible) to the intended size range in which the tested feed ingredient or feed would be used.

In the laboratory, enzymes for DH analysis are obtained from shrimp hepatopancreas under defined protocols. Crude enzyme extracts containing shrimp proteases and other important digestion co-factors are standardised according to the DH potential so that outputs are comparable among different enzyme extract batches. Enzyme extracts may be stored at -20 °C or below for use as required or the convenience of the analyst. At this temperature, shrimp proteases can remain stable for several months.

### Prediction of protein digestibility in ingredients and feeds for shrimp

Outputs from culture trials emphasise the significant and economically important variations in nutritional quality of feed ingredients. Ideal quality control in aqua feed manufacturing should involve the prompt assessment of raw materials by consistent analytical procedures with nutritional features rapidly determined. *In vitro* DH values were

Table 1. Some ingredients and respective analysed composition (%) used to measure *in vivo* and *in vitro* protein digestibility.

	Crude protein	Fat	Ash	Moisture
Feather meal (USA)	79.8	9.8	2.9	6.1
Fish meal (Anchovy, Peru)	66.9	11.5	15.1	4.4
Fish meal (Hoki, New Zealand)	65.3	6.9	19.8	4.2
Fish meal (Mackerel, Chile)	70.3	4.0	17.4	6.4
Fish meal (Menhaden, USA)	66.0	8.5	19.2	3.9
Krill meal (USA)	67.9	6.2	9.6	7.3
Poultry by-product meal (USA)	64.9	11.2	16.3	2.9
Soybean meal (Dehulled, solvent extract)	47.7	0.8	7.2	7.1
Soybean meal (Full-fat, extruded)	40.1	19.6	5.6	5.1
Soy protein isolate	83.6	3.8	3.3	8.6
Squid (Muscle meal, Peru)	81.8	3.9	3.3	8.6
Squid (Muscle meal, Paita)	83.8	4.5	3.6	6.7
Wheat gluten (USA)	75.9	4.7	3.9	7.4

Figure 4. Correlation between protein digestibility in live shrimp and *in vitro* DH values with shrimp enzymes using 25 compound feeds for juvenile shrimp *L. vannamei*.

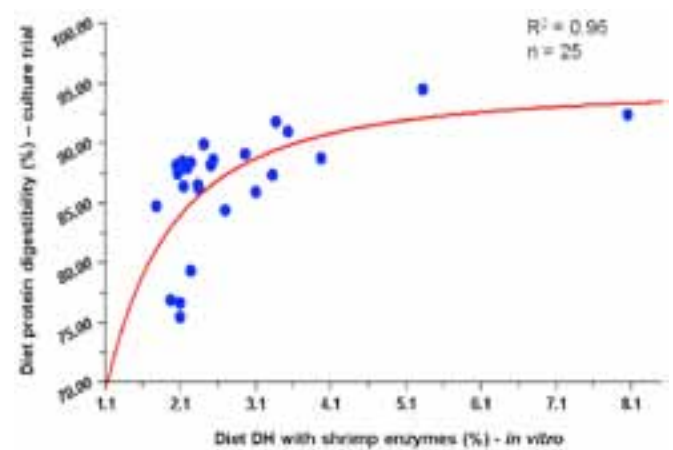

significantly correlated with digestibility outputs from trials with live juvenile shrimp *Litopenaeus vannamei*. (Figure 3).

The model obtained for raw materials included 26 different ingredients from several types and sources including meals from plants, rendered animals and marine sources (Table 1). The prediction of protein quality is feasible by the conversion of *in vitro* values (DH) into digestibility through the correlation model that describes the *in vivo* – *in vitro* relationship. The DH with shrimp enzymes has also shown able to predict protein digestibility of compound feeds in live shrimp trials (Figure 4). The model describing the relationship for compound diets is similar to that verified for raw materials and enables the prediction of protein digestibility in finished feeds.

To date over 2,000 samples of ingredients and feeds have been analyzed for DH in our laboratory. Table 5 shows the observed *in vitro* protein digestibility values for some plant and animal meals for farmed shrimp (Figure 5).

Correlations between *in vivo* protein digestibility and DH suggest a close relationship between breakage of protein peptide bond by shrimp digestive proteases and assimilation in live shrimp and this may be a useful tool to provide rapid nutritional information. As an enzymatic tool, DH is particularly sensitive for anti-nutritional factors contained in feedstuffs such as digestion inhibitors.

The DH is an indication of protein quality and the method may be a tool for manufacturers in the selection and quality control of raw materials, as well as in the evaluation of finished feeds with regards to the effects of formulation and processing upon feed digestibility. Ingredient suppliers may also benefit from quality control in advanced processing strategies to generate 'value-added' raw materials to be included into modern aqua feeds. DH combined with the amino acid profile data may be useful for the assessment of feed protein quality in terms of nutrient content and availability.

Figure 5. *In vitro* predicted protein digestibility of feed ingredients from different types and sources for juvenile shrimp *L. vannamei*.

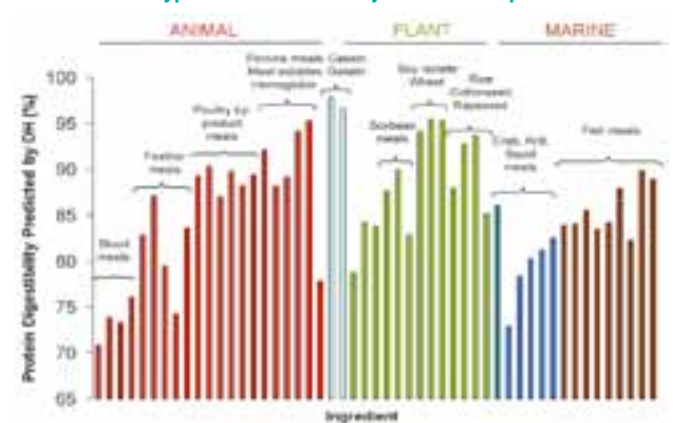

## Set-up cost for DH analysis (shrimp) and output rates

Summing up the advantages of cost and time expenditure for *in vitro* analysis the laboratory set-up asset for DH method is very low compared to costs for determination through *in vivo* digestibility trials that often involve culture facilities, extensive experimental periods and labour.

Automatic potentiometric titrator with pH-stat function, simplest model, basic configuration = **between USD 14,000 and 17,000**

Supporting laboratory equipment (circulating water bath, pipette kit, refrigerated microcentrifuge, glassware) = **between USD 14,000 and 18,000**

Output rate: the sampling of 600 hepatopancreas from 6 to 8 g shrimp may render over 600 analyses. Up to 12 determinations may be carried per day (12h labour routine) with the simplest automatic titrator model.

## Further reading

- De Muylder, E., Lemos, D., van der Velden, G., 2008. Protein hydrolysis of processed animal proteins shows the nutritive value for shrimp feeds. *Aqua Culture Asia Pacific*, Sept/Oct: 18-19.
- Lemos, D., Ezquerro, J.M., Garcia-Carreño, F.L., 2000. Protein digestion in penaeid shrimps: digestive proteinases, proteinase inhibitors and feed digestibility. *Aquaculture* 186, 89-105.
- Lemos, D., 2004. Enzymatic determination of hydrolysable protein: a species-specific tool for quality control of ingredients and feeds. *Int. Aqua Feed* 7, 32-34.

- Lemos, D., Córdova-Murueta, J., Navarrete del Toro, A., Garcia-Carreño, F.L., 2004. Testing feeds and feed ingredients for juvenile pink shrimp *Farfantepenaeus paulensis*: *in vitro* determination of protein digestibility and proteinase inhibition. *Aquaculture* 239, 307-321.
- Lemos, D., Nunes, A.J.P., 2008. Prediction of culture performance of juvenile *Litopenaeus vannamei* by *in vitro* (pH-stat) degree of feed protein hydrolysis with species-specific enzymes. *Aquac. Nutr.* 14, 181-191.
- Lemos, D., Lawrence, A.L., Siccardi III, A.J., 2009. Prediction of apparent protein digestibility of ingredients and diets by *in vitro* pH-stat degree of protein hydrolysis with species-specific enzymes for juvenile Pacific white shrimp *Litopenaeus vannamei*. *Aquaculture* 295, 89-98.



Daniel Lemos



Albert G. J. Tacon

Daniel Lemos is Professor, Head of Aquaculture Laboratory (LAM), Oceanographic Institute, University of São Paulo, Brazil. Email: dellemos@usp.br

Albert G. J. Tacon is Visiting Professor, Instituto de Investigaciones Oceanológicas, University Autónoma de Baja California, Ensenada, México. Email: agjtacon@aol.com



## Process technology, machinery, and complete plants for the aqua feed industry

- New process lines and plants ■ Process equipment upgrades and replacements
  - Spare and wear parts ■ Service and maintenance programs ■ Optimization and support
  - Leading technologies ■ Global presence ■ Local service
- Together, we make it work!

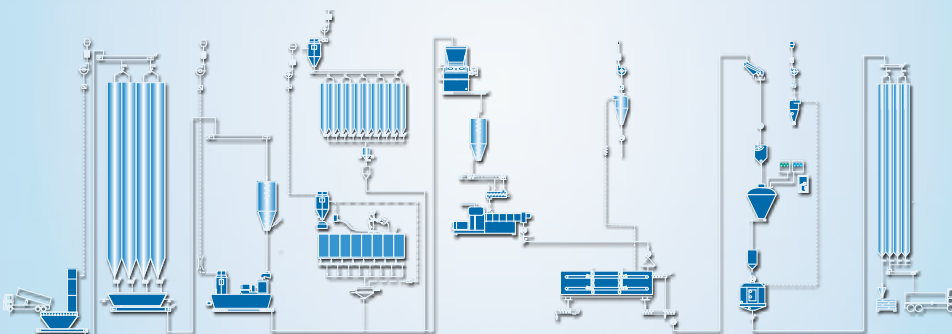

ANDRITZ FEED & BIOFUEL supplied in 2008, a complete system to Emsland-Aller Aqua. With Europe's most modern fish feed factory, in Golßen, Germany, Emsland-Aller Aqua has an excellent facility for testing product innovations. Using the most modern machines available, for example the latest in extruder technology, product developments can also be put into practice quickly.

ANDRITZ FEED & BIOFUEL  
Rep. office Vietnam  
Phone: +84 8 6253 9434  
andritz-fb.vi@andritz.com

ANDRITZ FEED & BIOFUEL  
Division of ANDRITZ Technologies Ltd. P.R. China  
Phone: +86 21 64670285  
andritz-fb.cn@andritz.com

www.andritz.com

# Dietary potassium diformate improves performance of white shrimp production under controlled conditions

By Kai-J. Kühlmann, Orapint Jintasataporn and Christian Lückstädt

**A promising ingredient in modern shrimp nutrition based on effects on growth in laboratory trials in Thailand.**

In aquaculture, it has been established that the use of antibiotic growth promoters as an in-feed additive for the diets of fish and shrimp promote growth and feed conversion as well as improve survival rates. However public concerns, especially in the EU, on the development of cross-resistance to humans have led to a ban or decrease in the use of such substances worldwide. Consequently, research focussed on other additives in order to maintain performance parameter and high survival rates in aquaculture.

Acid preservation of fish and fish viscera to produce fish silage has been a common practice and its final product has been widely used in fish feeds with reported beneficial effects (Gildbert and Raa 1977; Åsgård and Austreng 1981). According to Batista (1987) the fish silage production was initiated in the 1930s, first with sulphuric and hydrochloric acid preservation of fish waste. The production of acid-preserved fish silage can be achieved either with organic or inorganic acids or their blends. If inorganic acids are used the pH of the silage has to be lowered to pH 2 or below in order to obtain a fully preserved product. Therefore, before feeding this type of silage to animals, neutralisation needs to take place.

## Direct fed fish by-products

On the other hand, if organic acids such as formic or propionic acid are used, the silage is stable at pH 3.5-4.0 enabling the silage to be directly fed without neutralisation. Due to this advantage, most silage producers use recently organic acids. Fish silage or liquefied fish protein is an effective way to convert fish by-catch and fish processing by-products into a nutritive feedstuff for a wide variety of animals, such as poultry (Balios 2003).

Kotzamanis (2007) used 2.2% formic acid inclusion to produce sardine (*Sardine pilchardus*) fish hydrolysates as starter feed for sea bass (*Dicentrarchus labrax*) larvae. The hydrolysate was incorporated into the diet at two different levels; 10% and 19% of total ingredients. Results on performance showed that the inclusion of the fish hydrolysate gave similar results on growth after 33 days of feeding, compared to an enzymatic fish hydrolysate (except the low inclusion of fish silage which had lower wet weights), but the fish silage could significantly improve ( $P < 0.05$ ) the survival rate of sea bass larvae orally challenged with *Vibrio anguillarum*.

The beneficial effects of acid preserved products has caught the attention of the scientific community and has led to investigations on the direct effects of these short-chain acids in fish feed. Several studies were conducted with different species such as the rainbow trout *Oncorhynchus mykiss*, Atlantic salmon *Salmo salar* and arctic charr *Salvelinus alpinus* and herbivorous filter feeders (tilapia) and omnivorous fish (carp, catfish).

## Organic acids in aquaculture

Following experiences in swine and poultry feeding, a wide variety of organic acids, their salts – as well as their blends have been tested in aquaculture diets (Table 1).

**Table 1. Formulas, physical and chemical characteristics of organic acids used as dietary acidifiers in aquaculture (modified after Foegeding and Busta 1991).**

Acid	Formula	MM (g/mol)	Density (g/ml)	Form	pK-value
Formic	HCOOH	46.03	1.22	liquid	3.75
Acetic	CH <sub>3</sub> COOH	60.05	1.05	liquid	4.76
Propionic	CH <sub>3</sub> CH <sub>2</sub> COOH	74.08	0.99	liquid	4.88
Butyric	CH <sub>3</sub> CH <sub>2</sub> CH <sub>2</sub> COOH	88.12	0.96	liquid	4.82
Lactic	CH <sub>3</sub> CH(OH)COOH	90.08	1.21	liquid	3.83
Sorbic	CH <sub>3</sub> CH:CHCH:CHCOOH	112.14	1.20	solid	4.76
Malic	COOHCH <sub>2</sub> CH(OH)COOH	134.09	1.61	solid	3.4, 5.1
Citric	COOHCH <sub>2</sub> C(OH)(COOH)CH <sub>2</sub> COOH	192.14	1.67	solid	3.13, 4.76, 6.4

MM = Molar mass

Currently the most widely tested organic acid molecule in aquaculture is potassium diformate (KDF). Potassium diformate is a double-salt formic acid molecule which decreases gastro-intestinal pH and thereby intensifies release of buffering fluids, containing enzymes, from the hepato-pancreas on the one hand. Formate on the other diffuses into pathogenic bacteria inside the digestive tract and acidifies their metabolism, leading to pathogenic bacteria death. Furthermore, beneficial bacteria (*Lactobacilli*, *Bifidobacteria*) are supported (eubiosis) which may lead to gut health, resulting in a stronger condition of shrimps.

## Organic acid and growth of shrimp

Pond production of intensively farmed white shrimp, *Litopenaeus vannamei* has exceeded 2 million tonnes in Central America and SE Asia in 2007 (FAO, 2010), which had only been achieved through high-quality shrimp feed supply in modern aquaculture. Despite strong progress in shrimp nutrition and new feed formulation strategies during the past years (Hardy 2009), disease outbreaks in shrimp ponds resulted in production setbacks with increased use of antibiotics.

As information on the use of organic acids and their salts as dietary supplement in shrimp diets are still incomplete, this aquaria-simulated intensive grow-out trial aimed to investigate the growth performance of juvenile white shrimp fed with low levels of dietary KDF inclusion versus a control diet to compare its growth performance under local conditions.

## Experimental details

For a 10 week experiment in a scientific laboratory, 30 aquaria of 120 liters each, connected to a flow-through system, were filled with 20 ppt

**ROVIMAX® NX**



# Stronger fish make stronger profits and ROVIMAX® NX makes both

Your fish and shrimp will jump at the chance to build stronger defences against disease.

Introducing ROVIMAX® NX, a yeast product with a rich and balanced content of nucleo-

tides known to improve the performance of aquaculture production.

It's a safe, effective and natural lift for your fish, your productivity and your margin.

**DSM Nutritional Products Asia Pacific Pte Ltd**  
2 Havelock Road #04-01, Singapore 059763  
Tel: +65 66326500  
[www.dsmnutritionalproducts.com](http://www.dsmnutritionalproducts.com)

**DSM Nutritional Products**  
Aquaculture Centre Asia Pacific  
17/1 Fl., Maleenont Tower, 3199 Rama IV Road  
Klongton, Klongtoey, Bangkok 10110, Thailand  
Tel: +66 (0) 2264 9800, Fax: +66 (0) 2264 9899

**HEALTH • NUTRITION • MATERIALS**



sea water of  $28.0 \pm 2.0^\circ\text{C}$  containing  $>6.0$  ppm of dissolved oxygen. Each aquaria was stocked with 18 shrimp of average individual body weight  $2.4 \pm 0.1$  g ( $n=540$ ). While control diet (treatment A) did not contain KDF, 0.2% and 0.5% KDF were added to diets in treatments B and C, respectively. Shrimp were fed to satiation three times a day with a commercial diet (Table 2).

**Table 2. Experimental diet containing 32% crude protein with KDF inclusion (modified after Millamena and Trino 1994).**

Raw material (g 100g <sup>-1</sup> ) <sup>a</sup>	A	B	C
Wheat starch	20	20	20
Animal protein meal: fish meal	25	25	25
Plant protein meal (soybean meal)	25	25	25
Vitamin C	5	5	5
Mix oil	10	10	10
Binder	8	8	8
Vitamin mineral premix	7	7	7
KDF	0	0.2	0.5
Total	100	100.2	100.5
Proximate Analysis (% of DM) <sup>b</sup>			
Dry matter (% of FM)	89.78	89.13	89.35
Protein	32.56	32.22	32.43
Fat	6.89	6.74	6.60
Fiber	2.39	2.42	2.40
Ash	9.40	9.36	9.45
NFE	48.76	49.26	49.12
Ca (%)	2.73	2.26	2.55
Phosphorous (%)	0.99	0.95	0.95
Gross energy(KJ g <sup>-1</sup> )	19.31	19.37	19.39

<sup>a</sup>A = control diet, B = diet with 0.2% KDF inclusion, C = diet with 0.5% KDF inclusion  
<sup>b</sup>DM = Dry Matter, FM = Fresh Matter, NFE = Nitrogen Free Extracts, after AOAC (2000)

### Improved growth

Results show an improved growth performance, feed conversion and productivity index of shrimps having received KDF containing diets compared to those fed on the control diet (Table 3). After the 10-week aquaria trial, individual body mass of KDF fed shrimps reached 11.8 g

**Figure 1. Body mass development of *L. vannamei* fed with KDF inclusion under controlled laboratory conditions.**

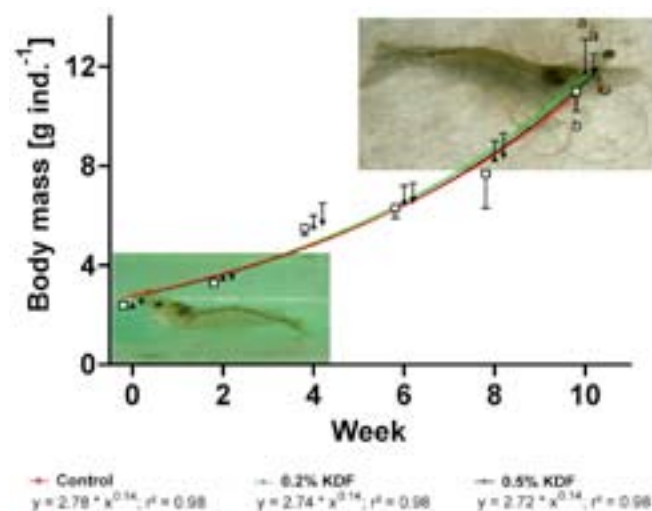

(B and C) compared to control group (11.0 g, A), thereby significantly ( $P < 0.05$ ) increasing the final body mass by 7.2% (B) and 7.4% (C) compared to the control group (A, Figure 1).

Total weight gain of 9.4g was higher for shrimps fed diets with KDF (B and C) compared to the control group (8.6g, A) leading to a 9% higher weight gain. Specific growth rate of 2.26% (B) and 2.25% (C) was higher compared to control shrimps (2.16%, A) resulting in 4.4% and 4.0% increase for KDF fed shrimp. Survival rate was 6% higher in 0.5% KDF fed shrimps (C) only compared to treatments A and B, while FCR was 7% lower for shrimps fed on KDF including diets.

**Table 3. Growth performance of shrimp fed with different KDF concentrations incorporated into the compound feed.**

Parameters	Diet Treatments		
	A	B	C
Initial body weight (g/ind)	2.4±0.1	2.4±0.1	2.5±0.1
Final body weight (g/ind)	11.0 <sup>b</sup> ±0.8	11.8 <sup>a</sup> ±1.3	11.8 <sup>a</sup> ±0.7
Weight gain (g)	8.6±0.9	9.4±1.3	9.4±0.7
SGR (%)	2.2±0.1	2.3±0.2	2.3±0.1
Survival (%)	76.1±7.0	76.1±4.6	80.6±13.4
FCR	1.47±0.1	1.37±0.2	1.37±0.1
Productivity Index (PI)	45.0 <sup>b</sup> ±8.5	53.8 <sup>a</sup> ±14.5	55.9 <sup>a</sup> ±14.0

Means with different superscripts within rows are significantly different ( $P < 0.05$ ).  
 SGR = Specific Growth Rate, FCR = Feed Conversion Ratio,  
 WG = Weight Gain, PI = WG x Survival / (FCR x 10)

The shrimp productivity index of the simulated shrimp grow-out increased significantly ( $P < 0.05$ ) to 3.8% (B) and 19.5% (C) due to KDF inclusion compared to shrimp fed on a control diet.

As laboratory trials are conducted in a rather controlled clean environment, higher effects of KDF are anticipated under natural pond conditions due to various pathogens provoking heavy mortalities and financial losses during farming operation. Thus, using dietary KDF inclusion in compound shrimp feeds pose a promising alternative in modern shrimp nutrition to improve white shrimp grow-out operation in ponds.



Dr. Kai Kühlmann      Dr. Orapint Jintataporn      Dr. Christian Lückstädt

Dr. Kai Kühlmann is Application Marketing Manager at Addcon Asia Co Ltd, Thailand, in charge in promoting feed additives in the SE-Asian aquaculture industry. Email: kai.kuehlmann@addcon.net

Dr. Orapint Jintataporn is with Kasetsart University, Faculty of Fisheries, Department of Aquaculture, Bangkok, Thailand and conducted the experiment. Email: ffora@ku.ac.th

Dr. Christian Lückstädt is based in Bonn, Germany, but serves as the Technical Director for Addcon Asia. He is responsible, among others, for the aquaculture product range of the group. Email: christian.lueckstaedt@addcon.com

# Understanding biofloc in aquaculture production systems

By Stephen G. Newman

Since 2009, protein from aquaculture production has surpassed that of fisheries for the first time in history. Aquaculture is simply a water-based agriculture with a long history. It is an essential source of nutrition, as well as a source of income for large number of communities. Aquaculture is here to stay, despite opposition to aquaculture from segments of the NGO community and commercial fisher folk. It is also certain to play an ever increasingly important role in feeding the Earth's burgeoning population.

However, as aquaculture practices intensify, environmental concerns and economic pressures oblige companies to conform to what are being termed best aquaculture practices or best management practices. These approaches to management are an attempt to bring consistency and ensure sustainability to the myriad of diverse practices world-wide. Control of waste streams and minimising environmental impacts at all levels are critical.

## Recycling waste products

Aside from protein for consumption and by-products of processing (offal), the major by-product of the production process from the various culture systems is sludge. This sludge is rich in nutrients, typically nitrogen and phosphorous, as well as a host of macro and micronutrients. After each crop, it must be disposed off properly, in a manner that is consistent with avoiding nutrient enrichment (i.e.

pollution) of the surrounding water environment. There are a number of different ways to get rid of this material including in-situ digestion with bacteria (conceptually confused with probiotics). Many microbial based products in the market today being sold as 'probiotics' function by digesting accumulated waste organic matter.

In sedimentation ponds, there is bioflocculation and direct disposal into receiving waters or burial into pits, etc. Flocculation refers to changes in the nature of suspended particulate materials that allow them to form aggregates or small clumps. In many waste treatment systems, this is done using chemicals such as alum, chitosan or other similar materials that impact the electrical charge of the particulates. It can also be done as well by the use of microbes and/or their metabolites (bioflocculation). These processes allow for handling of excess nutrients for easier disposal and are commonly used in the treatment of high organic content waste materials produced in human sewage treatment plants.

Naturally ahead

≡ **Biomin** <sup>®</sup> ≡

## BIOMIN AQUA Product Line

### *Specific Action – Effective Solutions*

**AquaStar**, high performance probiotic strains to enhance gut and pond environment.

**HepaProtect Aqua**, an effective solution to support and protect liver metabolism.

**Mycofix** <sup>®</sup>, the most complete strategy for counteracting mycotoxins.

**Biomin** <sup>®</sup> **P.E.P.** for improving digestion and feed conversion.

For enquiry, please e-mail

[aqua@biomin.net](mailto:aqua@biomin.net)

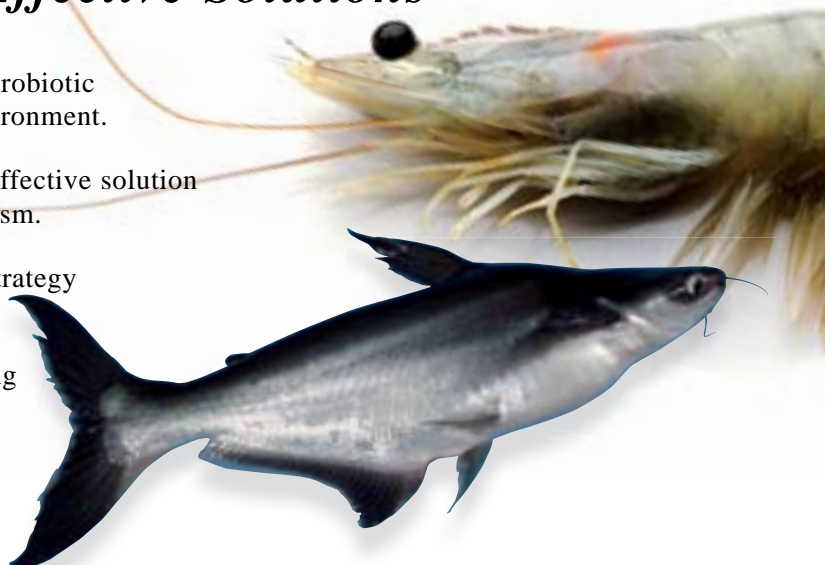

[www.aqua.biomin.net](http://www.aqua.biomin.net)

## Biofloc

In aquaculture, this flocculation process is being exploited in a modified form in fish and shrimp culture ponds. The term biofloc has been coined to apply to these particulate materials when they are generated in very low or zero exchange water systems principally through the action of bacteria and other microorganisms. Actually, the concept is not new as it has been used for a long time in sewage treatment plants. It is only within the last two decades, that this concept is widely applied in aquaculture.

In pond environments, this is recycling in the truest sense of the word. Almost 30 years ago, Steve Serfling discovered the potential of biofloc in the production of tilapia. Considerable research has been done since then and biofloc systems are often found in intensive shrimp and fish farming systems globally.

## Explaining biofloc

The term biofloc is synonymous with many others, including microbial floc, organic detrital soup, intensive microbial reuse systems, etc. Usually there is never a consistency in terms of composition between farms (and even ponds within a farm). These particulate suspensions of organic matter are composed of a wide variety of living organic and in many cases inorganic matter as well. The typical composition can include a myriad of different species of bacteria, fungi, algae, protozoa, nematodes and other microscopic organisms. This is a complex ecosystem and is in some aspects related to biofilms that typically colonise surfaces.

The generation of biofloc depends on high levels of organic matter in the ponds, usually the common by-products of culture such as faecal material, uneaten feed, dead algae and other plant and animal materials and a proper balance between carbon and nitrogen levels. As with all ecosystems, there is a succession of stages and the process will eventually result in a stable floc.



*Stages of biofloc formation. A stable floc produced from the particulate suspensions of high levels of organic matter needs a balance of C:N ratio, aided by carbohydrate inputs such as molasses. The suspension requires high aeration to keep particles suspended. Fish/shrimp consume the highly nutritious biofloc and additional inputs include less costly feeds. Ammonia nitrogen is broken down into nitrates.*

## Why biofloc

The primary advantage of these systems is with high density production systems. Here there is limited or no water exchange, resulting in economic, environmental and production advantages. This means savings in electrical costs with a reduction in pumping water. However, the risk is that high levels of aeration for oxygenation and water agitation is essential to ensure that the particles remain suspended in the water column. Some of the reported benefits are:

- A low or zero exchange system will have a decreased reliance on water during the production cycle. In turn, with a concomitant increase in biosecurity, the closed system decreases the risk of introducing pathogens or potential pathogens that may be present in the incoming water.
- There is a significant decrease in the amount of water resources required to produce the crop. Many of these systems require no water exchange during the cycle and typically, any incoming water is to make up for evaporation.
- The reuse of the pond water translates to a very small environmental footprint, both from the standpoint of water usage and the potential for impact from effluent that is discharged during harvest, etc.
- Reusing water is a component of sustainability. Furthermore, effluents, which are largely free of nutrients, will reduce the environmental footprint.
- The system allows for in-situ nutrient recycling. In conventional open culture systems, most of the nutrients that are not consumed and the rich nutrient content of faecal material and the huge biomass that exists in ponds are wasted. In biofloc systems this is not the case. This applies to nitrogenous nutrients particularly protein and carbohydrates as well. Micronutrients are also recycled in this manner.
- There is less reliance on external sources of feed for growth. Bioflocs are highly nutritious and are readily consumed by many species of fish and shrimp. Less costly feeds containing lower levels of nitrogen (protein) with concomitant lower feed conversion ratios can be used as supplementary feed.
- The cost of production is reduced and also lessens the potential environmental impact of these operations by allowing production of animals that require less fish meal and fish oils to produce.

Positive impacts on animal health include immunity and nutritional status. The biofloc system supports denitrification by the breakdown of ammonia nitrogen into biologically benign forms of nitrogen such as nitrates.

## A tool and not a solution

It should be noted that biofloc system is a tool. It is not a solution and is not a substitute for progressive management strategies that encompass proper biosecurity protocols, appropriate feeding regimes and feed management strategies, monitoring for water quality parameters, that can negatively impact animals, proper disposal of excess accumulated

**AquainTech Inc.**  
Aquaculture Information Technology

Consulting for Sustainable Aquaculture  
([www.shrimpaquaculture.com](http://www.shrimpaquaculture.com))

Ph.D. marine microbiologist and ecologist with >30 years of international experience in all facets of production of multiple species (finfish and crustaceans).

Technical and operational audits for investors, banks, insurance companies, NGOs, Certifying Bodies, processors and producers at all levels of production.

Trouble shooting problems at any and all levels of production with goal oriented results geared towards increasing profitability.

---

Products for Sustainable Profitable Aquaculture  
([www.aqua-in-tech.com](http://www.aqua-in-tech.com))

Microbial tools for sludge removal and bioremediation

Innovative competitively priced products for maturation, hatcheries, farms, feed mills and processing plants. Feeds, feed ingredients and supplements, disinfectants, WSSV diagnostic test kits, probiotics, krill and krill products for maturation and hatcheries, polychaetes, artemia biomass, artemia cysts, Spirulina, algal meals, fucoidan and glucans.

Contact Information: AquainTech Inc. 425-787-5218  
[snewma@gmail.com](mailto:snewma@gmail.com)

sludge at harvest time, etc. There is not a single universal set of guidelines that can be followed, i.e. a recipe, for the production of biofloc. There are, however, some consistent features of these systems and understanding what they are and ensuring that the system is conducive to the formation of these particulate materials will go a long way towards ensuring that a degree of reproducibility is achieved.

- High biomass. High animal densities result in higher nitrogen levels from faecal material and feed waste that diffuse into the water from the feed prior to it being consumed. Particularly in the case of shrimp, these are added to the water column because of the way the shrimp feeds.
- Aeration. Vigorous aeration is required to keep the particles in suspension and to encourage their formation.
- Ratio of carbon to nitrogen. These range from about 10:1 to 20:1. The ratio has to be determined experimentally for each operation. Flocs do not form immediately and typically, the addition of molasses or other soluble carbon sources is needed to optimise conditions for biofloc formation.
- Consumption by fish/shrimp. The ability of the organisms being produced in these systems to consume the particulates. In order to prevent the accumulation of these materials from becoming rate limiting they must be removed from the system. Clearly the solution that makes the most sense is when they are eaten by shrimp (*Litopenaeus vannamei* or other omnivorous benthic grazing species) and fish (Tilapia species, some catfish species, etc.). Any other method for removal would add costs that might not be acceptable.
- Diet reformulation. Sources of sulphur in the diets and diet formulations that are not consistent with the buildup of toxic levels of micronutrients. In any system, that is largely if not completely closed, it is critical that diet formulations take this into account or the system can crash from the accumulation of metals and other potential inhibitory materials.

### Useful but....

In conclusion, the production of suspended particulate biofloc in aquatic production systems is a very useful tool for improving profitability, biosecurity and lessening the environmental footprint of aquaculture. It enhances sustainability and the eco-friendly nature of aquaculture.

Not all systems lend themselves to this approach. For those that do, generation of these high nutritious and water chemistry moderating amalgams of organisms and nutrients are an essential element of a responsible and consistent production system.



**Stephen G. Newman Ph.D** is President and CEO of AqualnTech Inc. Newman earned his PhD in marine microbiology in 1979 from the University of Miami. He was instrumental in the development, sales and marketing of the first vaccines for fish and is an internationally recognized expert in the development of vaccines and drugs for aquaculture. In his more

than 30 years of working with the international aquaculture community he has worked with companies, banks, insurance companies, governments and NGOs in dozens of countries on a wide range of projects dealing with most facets of the science behind aquaculture including pathology, immunology, genetics, nutrition, water quality, endocrinology, biochemistry, diagnostics, certification, development of sustainability, microbiology. AqualnTech Inc., founded by Dr. Newman in 1996, provides a wide range of consulting services and products that are geared towards promoting science based sustainable aquaculture. Email: [sgnewm@aqua-in-tech.com](mailto:sgnewm@aqua-in-tech.com) Web: [www.aqua-in-tech.com](http://www.aqua-in-tech.com) and [www.shrimpaquaculture.com](http://www.shrimpaquaculture.com)



AwF-Bishramganj, India Project

## Together we can achieve wonderful things.

Dear industry colleague,

AwF welcomes donations in many different ways. Financial donations are great but we value your aquaculture industry expertise and skills even more.

Highly trained professionals like you have a great deal to offer your colleagues in developing countries. Whether it's sparing a little time to advise on one of our current aquaculture projects or donating some equipment, you and your organization can help in so many ways.

Please contact AwF today to see how you and your team can help. Together we can achieve wonderful things.



[www.aquaculturewithoutfrontiers.org](http://www.aquaculturewithoutfrontiers.org)

...be a part of something special.

# THE AQUACULTURE ROUNDTABLESERIES 2011

## A shared vision for aquaculture in Asia

### AQUACULTURE FEEDS & NUTRITION

17-18 August 2011, Holiday Inn Atrium, Singapore

#### THE PERFECT PLATFORM FOR STAKEHOLDERS TO COME TOGETHER AND SHAPE THE FUTURE!

While modern aquaculture has been around for the past 40 years, it has not developed at the speed expected of an industry that has the enormous responsibility of creating an alternative source of seafood to the dwindling capture fisheries. One of the major contributing factors is the lack of direction, coordination and technology development to propel the industry forward.

The Aquaculture Roundtable Series 2011 (TARS) provides a platform for stakeholders to address the challenges and formulate a clear strategy, and provide a roadmap for the future. The result should be a self initiative to direct the development in a guided manner, yet allow for opportunities to 'think outside the box'. The benefit should come from the synergy of networking and creating efficiencies.

#### MODUS OPERANDI OF THE ROUNDTABLE

##### WHERE ARE WE TODAY?

International experts will address:

- State of the industry
- Current knowledge on nutrition and feed technology
- Emerging trends affecting sustainable growth and profitability

##### WHERE WILL WE BE TOMORROW?

Participants in breakout groups will:

- Deliberate on future challenges impacting feeds for fish and shrimp
- Identify priority areas for research and development
- Propose directions to move forward



The Aquaculture Roundtable Series 2011

*Developed as a series to cover all sub-segments of the industry, the inaugural TARS 2011 will focus on AQUACULTURE FEEDS & NUTRITION.*

#### LIMITED SEATS - REGISTER EARLY!!!

Early bird (until 25 May 2011) - SGD 650  
From 26 May 2011 - SGD 800

Organisers:



AquaResearch Pte Ltd

Supported by:



Sponsor:





## A Singapore contribution to a regional industry By Zuridah Merican

**It is important that farms begin production with high health fry and fingerlings and farmers are encouraged to practise good farm management.**

High health fry is the *raison d'être* of the Marine Life Aquaculture (MLA) multispecies hatchery in Pasir Ris in the northern coast of Singapore. MLA is an integrated aquaculture company and supplies vaccinated and tested disease-free fry and fingerlings of the barramundi, *Lates calcarifer* to farms in Malaysia, Singapore, Indonesia and Hawaii. Production is from a biosecure land based 1,000 m<sup>2</sup> intensive facility complete with an integrated program in fish health surveillance. MLA also works with farmers to achieve better production through higher survival rates and yields.

However, in line with its future plan to be a regional fry supply hub, there are ten target species. Besides the barramundi, two other species already in commercial production are the golden trevally, *Gnathanodon speciosus* and the four finger threadfin, *Eleutheronema tetradactylum*. It plans to start fry production for the crimson red snapper, *Lutjanus erythropterus*, tiger grouper *Epinephelus fuscoguttatus*, silver pompano *Trachinotus blochii*, Red drum (Taiwan threadfin) *Sciaenopus ocellatus*, grey striped mullet *Mugil cephalus*; marble goby *Oxyeleotris marmorata* and the freshwater prawn, *Macrobrachium rosenbergii*, once the intensive production protocols have been developed on closing the cycle. Grow-out production of selected species and the holding of brood stocks are carried out in a net cage farm.



*Golden trevally fingerlings at MLA.*

### The MLA barramundi

“For the moment, our core species is our MLA barramundi. The founder stocks came from a grow-out farm in Singapore which we then selectively breed with local stocks. In turn, the founder stock for the farm was the result of the selection for fast growth in an AVA selective breeding program



The MLA barramundi juveniles show a humpback chubby shape with a shorter tail and fins are darker. In comparison, native stocks are more whitish, have yellowish fins and elongated in shape.



This is the 4th batch of the four finger threadfin.

using Australian, Indonesian and local barramundi stocks. Thus, what we have now is the combination of attributes: fast growth, from 0.1g to 650g in six months (as compared to 10 months for local stocks), wider body and darker pigmentation,” said Frank Tan, COO.

In the small aquaculture business in Singapore, Marine Life Aquaculture is a new entrant but within a short time, it has made a mark as a reputable supplier to some large marine fish farms in the region. It was set up in April 2009 by a group of friends led by Frank Tan and Tan Kay Hock, chief technical officer cum shareholder. By the end of 2010, production capacity had reached 1.11 million fry and fingerlings.

### Self regulation and biosecurity

MLA is very proud of its biosecurity practices. Frank Tan said that it is the responsibility of MLA to provide top quality fry and fingerlings guaranteed as disease free. At the hatchery, visitors are not allowed into the farm if they have been to another farm in the past two days. MLA is also self regulating itself.

“Although unregulated, we have set the standard whereby all the fry and fingerlings undergo pre-delivery health screening for diseases. Fish are sent to the National Laboratory of the Agri-Food & Veterinary Authority and Intervet for full screening of VNN (Viral nervous necrosis), big belly, *T. maritimum*, iridovirus and *Streptococcus*. Additionally, we have developed a nanotechnology protocol for packaging fish in seawater with high dissolved oxygen which extends the transportation period to more than 72 hours,” said Frank Tan.

“Throughout the production cycle, the aim is to select for quality fry and fingerlings. Eggs are sterilised against VNN which is transmitted

vertically and is apparent before day 10 in the barramundi larval rearing. The first selection of the main group is done during the larval stage when we eliminate the slow growing and deformed fish. In this way, we select only the better performers which require a shorter culture period, thus benefiting the farmers. Sizing and culling start at day 15 and we can say that only 30% of the fish finally reach the nursery to grow out cycle,” said KH Tan.

“It is this culling process which enables us to have this lead with strong and quality fry and fingerlings. Our role is to help farmers overcome a major bottleneck in the marine fish farming business in the region, which is quality fry. However, along the production cycle, the farmer should in turn be able to practise good management at the farm and reap the benefits (see chart).

From the start, we have been working with Intervet Schering Plough Animal Health in Singapore and 1.5 to 2g (45 to 50-day old) barramundi larvae undergo bath immersion vaccination. Four inch or 12 gm fry is vaccinated by injection in the nursery cages. To minimise stress, culling and transfer to the different size cages are carried out during the process for bath treatments etc.”

### Sustainable production

According to both Tans, their intensive production in clear water, land based systems for the barramundi stands out among other hatcheries in the region which usually use green water technology. The clear water allows them to better monitor mortality, said KH Tan. He has a proprietary water treatment system for both new and recirculating water. Chlorination is essential for the incoming seawater which has a

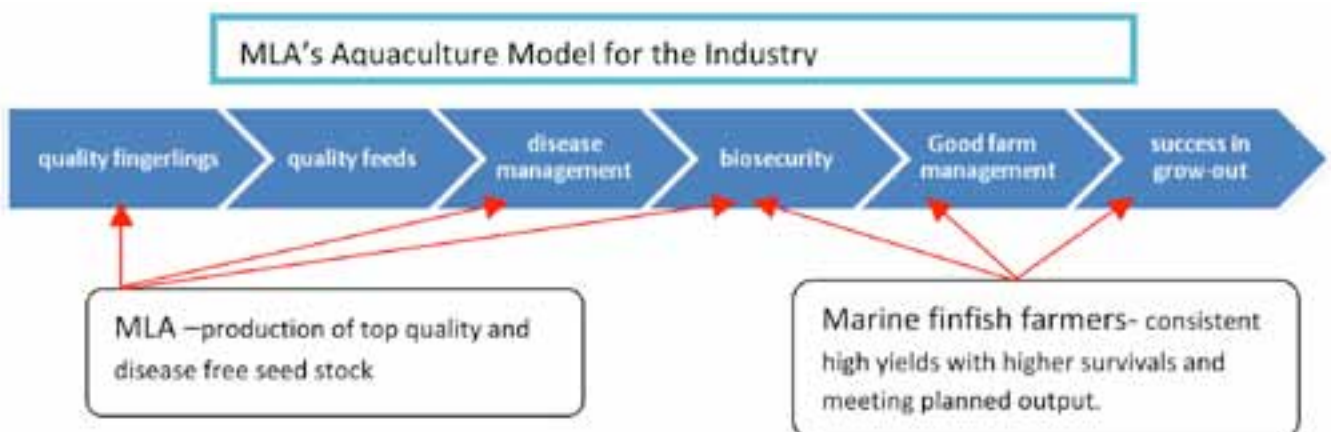

high bacteria count, high carbon dioxide and sometimes containing red tide organisms. Treatment starts with a cartridge filter and thereafter, either ozone or UV treatment. The more costly ozone treatment is used for the small volume of water for larval rearing tanks whereas UV sterilisation is used for the higher volume of water for the nursery tanks. Returning water goes through a protein skimmer, degassing, cartridge filtration and UV or ozone sterilisation.

“With the grading and selection, we have achieved an average survival of 30% from egg to fry/12g fingerling. This is much higher than the 10-20% in conventional open system hatcheries. We believe that controlled production in indoor facilities is important to achieve high survival rates. In Malaysia, tiger grouper are cultured in open systems and survivals range from 2-3% only,” said KH Tan.

“Another key factor to achieve quality fry is early weaning. Weaning starts at day7 for the barramundi and day10 for the four finger threadfin. In the case of the tiger grouper, it is my target to start weaning immediately after the *Artemia* feeding stage. In Indonesia, fry are only weaned after 5g size. We wean our fry on high performance micro particulate feeds from Japan, Belgium, France and Taiwan. There is no compromise here.”

### Some firsts

The team also reported some recent successes. The larval rearing of the marble goby, a delicacy in high demand in Asian seafood restaurants, has been achieved by using an expensive high performance marine larval feed. KH Tan is now trying with other feeds to cut costs.

In the case of the four finger threadfin, production is from its F1 generation. With its proprietary technology, MLA overcomes the mechanical shock problem which causes mortality at the 1g size stage. Currently, the production is 200,000 fry a month but all the fish are kept for grow-out at its net cage farm (see box).

### Marketing

The company sells fry and fingerlings of a large size range, depending on the demand from buyers. It has sold 30 day, 0.1g to 0.5g fry and 5g to 12g juveniles to large and small farms in Singapore and Malaysia. Much smaller fry of 0.05g (20 day) are air freighted to Indonesia.

“We get a price premium of 20% for our fry and fingerlings. Our advantage is that we have absolute control on quality as we do everything in-house. Our stocks show high health while conventional hatchery producers face disease problems because of parasites. So far, we have reports that our fry and fingerlings perform well in cage farms. Growth of the 2-inch golden trevally fry, sold to farms in Singapore and Malaysia reach 300g in 4.5 to 6 months as compared to the 10-12

months using fry from other producers. Survival rates are also good at 90% for the golden trevally, 70% for the barramundi and 70-80% for the threadfin,” said Frank Tan.

“Sales are direct to customers. Demand is increasing but our production is limited by space. The upside of the hatchery business is that we are not affected by the fluctuations in ex-farm prices of fish.”

### More space to expand

In the past year, the company has been running a pilot project on Pulau Ketam pending its expansion application. On approval, this hatchery and nursery will occupy 6ha. In this new facility, the team has targeted a 24 million annual production of 30-day larvae and 15 million of 12g fry in the next three years. Furthermore, to demonstrate its long term commitment to the industry, MLA will, as a self regulation measure, be discharging used water through wetlands on the island. This will be its contribution in conserving the environment. Another future endeavour for the company will be genotyping the brood stock to complement the phenotypic traits already achieved. This will lead to more specific genetic improvement.



Frank Tan (left) and Tan Kay Hock with a 5kg MLA barramundi brood stock at the cage farm. Frank Tan came from the oil and gas industry and has entered the aquaculture business with passion. KH Tan is a veteran in fish and shrimp aquaculture and was with the then Primary Production Department, Singapore for 30 years.

### Advancing its culture methodology

In Singapore, marine fish farming, which produces about 4,500 tonnes of fish annually is carried out in designated areas: three locations in the northern waters, two in the west coast and two in the southern waters, off Pulau Semakau.

MLA's net cage farm is located off Pulau Ketam and this is where it carries out the nursery culture of the barramundi and grow-out of the four finger threadfin to marketable sizes of 500g. Aside from grow-out in these cages, MLA provides the threadfin fry to 2-3 farmers and supports them with feed. The harvested fish is bought back and marketed in the local market.

A unique feature at the farm is the configuration of cages. Cage sizes start at 3mX3m and increase in size to 5mX10m to 6mX20m. MLA developed this and others are adopting this configuration, in particular for the barramundi.

Frank Tan is recommending this configuration for barramundi farming rather than in large circular cages. “The fish is different from the salmon which shows a uniform growth pattern. The barramundi shows an uneven growth and requires regular sizing. In the hatchery, we start sizing at day 10 and even in the nursery, we continue to size by manual transfer to larger cages. Otherwise when 12g fish are stocked and allowed to grow to 500g, we will find a large size variation.”

Due to its location, the farm faces serious biofouling of the nets within three days. Their option will be to change to knotless polyethylene nets manufactured in Indonesia. However, on the brighter side, ex-farm prices have remained high. The four finger threadfin sells for SGD15/kg ex farm whereas the barramundi sells at SGD 6.5/kg and golden trevally at SGD10/kg. The farm can now benefit from the stronger Singapore dollar. Previously, it used floating feeds from Malaysia. We can now change to higher-end larval and grow-out feeds from Europe, which have now become affordable, said KH Tan.

# Microdiets in sea bream larval production

By Nick King, Philippe Dhert, Eamonn O'Brien and Brett Newman

**Replacement of *Artemia* during the early weaning of sea bream resulted in 42% faster growth up to 67 days post hatch.**

A reliance on a finite live food source in larval aquaculture is becoming a potential threat for the further development of the industry with increasing concerns on biosecurity. Similar to harvest quotas for products from fisheries, some *Artemia* harvests are regulated and this has resulted in erratic availability since the late 1990s. In addition, these shortages result from natural changes in primary production. During the past decade environmental changes caused by direct and/or indirect human activities have gradually destabilised the fragile saline ecosystems.

*Artemia* cysts are typically collected in migratory bird sanctuary areas. Birds are potential vectors of undesirable pathogens such as white spot syndrome virus and lymphocystis. The potential presence of these pathogens often prompts the use of remedial protocols in *Artemia* such as the use of antimicrobial agents and disinfectants. These are not always approved by government agencies safeguarding the environment and food safety.

## Replacing *Artemia*

Seeking more sustainable hatchery production, Skretting has pioneered the use of its patent-protected microdiet Gemma Micro for *Artemia* replacement in marine hatcheries. During the past decade, this micro diet has progressed from that of a research diet to a commercial user-friendly diet, using several nutritional and manufacturing advances. Today it is replacing *Artemia* for approximately 200 million fish larvae. The latest micro diet contains a blend of marine algae that acts in a matrix with other ingredients to ensure a high standard of nutritional and physical properties.

The protein-fat balance of the diet is formulated with a high percentage of soluble hydrolysed marine proteins, marine fatty acids and phospholipids, to ensure good digestion, growth and development of the young larvae before and during metamorphoses. Additionally, refined manufacturing techniques ensure high particle stability and provide control over physical characteristics such as spreading and sinking speed.

Nutritional stability in the diet is important as it allows standardisation in hatchery operations and opens new possibilities for automation and industrialisation to relieve costs of production. For larval feeding, current technology makes it possible to produce this Gemma Micro within small, pre-defined particle size ranges starting at 75µm and gradually increasing to 500µm without any nutritional variability.

This is clearly an advantage over live feeds which constantly challenge larvae to 'leap' and ingest larger prey. While some larvae in the population will instinctively do this, others are left behind for a short period of time, thus creating a 'survival of the fittest' scenario which can result in an early disparity in size distribution among cohorts.

## The difference is in the particle count

Larvae ingest individual prey and thus it is interesting to compare particle count (number per gram) and particle mass (µg) between microdiet and *Artemia*. A gram of microdiet (GemmaMicro 150) contains approximately three times more particles than a gram of newly hatched *Artemia* nauplii. Additionally, a particle of GM150 has approximately

three times greater mass than a newly hatched *Artemia*. Considering the larvae's limited ability to seek out prey and the finite volume of the stomach, chances for feed encounter and survival are considerably increased by using the micro diet as competition decreases among larvae for prey/diet ingestion.

## Sea bream rearing protocols

Since 2008, GreatBay Aquaculture (GBA; Portsmouth, NH, USA) has partnered with Skretting in taking a methodical approach to adapt the standard production technique into *Artemia* replacement protocols. This has been done on a species by species basis starting with Atlantic cod as the first to undergo full transformation to *Artemia* replacement, since 2009. Subsequently, further trials and commercial productions have followed with Summer flounder, European sea bass and, most recently, Gilthead sea bream.

Shortly after hatch, larvae were stocked into a larval rearing tank that was integrated to a recirculation system used for marine fish production (Table 1). Rotifers were enriched with enrichment feed (Ori-Green, Skretting) at 250ppm for 2 hrs and fed to the larvae three times per day (05.00, 13.00, 21.00) according to standard practice that is based on visual inspection of plankton density immediately prior to the next feeding.

GSL-*Artemia* were enriched with the same enrichment feed at 400ppm for 12 hrs and fed to the control tank four times a day at 09.00, 15.00, 21.00, 03.00. Co-feeding and weaning of the *Artemia* replacement tank was performed according to the five stage protocol described below. Larvae in the control tank were weaned using a diet (Gemma Wean, Skretting). The trial lasted until the sea bream were graded at 67dph (days post hatch) and evaluated for survival, swim bladder inflation and deformity.

**Table 1. Sea bream feeding regime.**

	<i>Artemia</i> replacement	Control
Rotifers to size (TL)	2-30 dph 9.7mm	3-22 dph 7.5mm
<i>Artemia</i> to size (TL)	None	21-50 dph 14mm
Co-feeding size (TL)	18-21 dph 7.1mm	20-34 dph 9.2mm
Weaning to size (TL)	22-30 dph 9.7mm	34-50 dph 14mm

A five stage approach was taken whereby an initial co-feeding period is followed by three stages of rotifer meal reductions and ending with a post-weaning period (Table 2). During the co-feeding period, rotifers are fed to the larval tank in batches (i.e. 'meals'), and weaning diet is presented to the larvae for a period prior to each rotifer meal. Following co-feeding, rotifer meals are shifted (Stage 1) and dropped in succession (Stages 2 and 3) until the transition to diet is complete. Typically, a co-feeding or weaning stage is held for 2-4 days depending on characteristics of the species in production. With bream, 4 days of co-feeding were followed by 3 days at each weaning stage.

Feed was delivered using a vibratory feeder connected to a programmable timer that allowed specific feeding periods, frequency of feed events within each period and the durations of each feeding event.

**Table 2. Co-feeding, weaning, and post-weaning program for Gemma Micro with sea bream.**

Stage	Feed type	Rotifer (feed time)	Feeding period Feeding at	Frequency (minutes)
Co-feeding	GM75/150	13, 20, 05	10–12, 18–20, 03–05,	30
Stage 1	GM75/150	16, 20, 05	09–11, 13–16, 18–20, 03–05	20
Stage 2	GM150	20, 05	08–10, 12–15, 17–20, 01–04	15
Stage 3	GM150	20	07–10, 12–15, 17–20, 01–04	12
Post weaning	GM150		07–10, 12–15, 17–20, 01–04	12

### Early weaning gives faster growth

Sea bream larvae immediately began to feed on the microdiet 75/150 mix the first day of co-feeding (18dph; 330 degree days). 100% of the larvae sampled had accepted the feed after Stage 1 weaning; however, the weaning program was continued to allow a more gradual transition from rotifers. Weaning was complete by 30dph (560 degree days). Growth was similar between microdiet and control groups until the onset of weaning (Figure 1). In the treatment group, a short lag period during weaning was followed by a rapid growth rate that resulted in a larger mean size by day 36 post-hatch (672 degree days). These *Artemia* replacement fish continued to be larger than the standard fish following this growth divergence. By day 67 post-hatch the mean weight of the treatment fish was 0.27g compared with 0.19g for the control fish.

**Figure 1. Growth of sea bream in degree days (the GEMMA-Micro fed fish is shown at the bottom).**

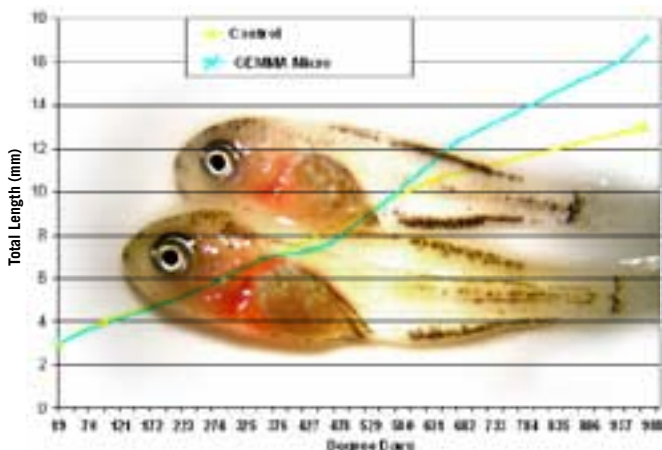

The survival of microdiet fed sea bream was similar to those in the control tanks and the fish exhibited greater pigmentation. In the treatment group 70% of the fish were separated as 'large' grade on a 3mm grader, and 30% were 'small' grade while in the *Artemia* control tank 30% were graded 'large' and 70% were separated as 'small'. No difference was noticed between the treatments in malformation of the fish.

Having the ability to remove *Artemia* from the production process for sea bream is a significant step to simplifying the production protocol in the hatchery. However, it is critical that this can be done without detriment to fish quality and economics.

For sea bream, the evidence from this trial and subsequent market feedback, suggests that fish weaned early using the microdiet grow faster and ultimately to a larger size than those fed *Artemia* and standard weaning diets. Similar results previously obtained with other species also showed the potential of this microdiet as an economic replacement for *Artemia* with benefits in terms of quality, growth and reliability of production.



Nick King



Dr. Philippe Dhert



Brett Newman

Nick King is Technical Manager, Skretting Marine Hatchery Feeds based in Portland, Maine, USA. Email: [nick.king@skretting.com](mailto:nick.king@skretting.com).

Dr. Philippe Dhert, Product Development Manager and Eamonn O'Brien, Product Manager, Marine Hatchery Feeds are with Skretting, Stavanger, Norway.

Brett Newman is Production Manager and Fish Health Specialist with GreatBay Aquaculture LLC, Portsmouth, NH, USA. Email: [BNewman@gbanh.com](mailto:BNewman@gbanh.com)



Eamonn O'Brien



[www.aquafil.com](http://www.aquafil.com)



We reclaim and buy all kinds of spent Nylon 6 fish nets (gill, purse, fish farm, trawl etc)

Think about environment!  
Don't sink the nets in the ocean

Those interested please contact us:  
Ladislao Labriola ([ladislao.labriola@aquafil.com](mailto:ladislao.labriola@aquafil.com))  
Tel: +39 0464 581105 / +39 348 3115102  
Fax: +39 0464 581129  
AQUAFIL S.P.A., Via Linfano 9, 38062 Arco (TN) – Italy

For Canada, North and South America:  
Jim Lindsey ([Jim.lindsey@aquafil.com](mailto:Jim.lindsey@aquafil.com)),  
Tel: +1 678 605 8149 Cell: +1 678 848 3416  
Aquafil USA, 10 Commerce Drive, Catterville, GA 30120 U.S.A.



## Grouper culture in peace agreement

In a project in the islands of Tawi-Tawi Province in Mindanao, Philippines, high value groupers and more recently, the tropical abalone are cultured in cages as part of industrial-estate fish farming. Surprisingly, some 1,000 farmers are former combatants from the recent conflict in the area.

*The new fish cage module at the Tawi Tawi Mariculture Park*

The USAID-GEM (Growth with Equity in Mindanao) represents a US government commitment to the 1996 final peace agreement between the Philippine government and the Moro National Liberation Front (MNLF) and the fisheries component project is GEM 3's Sustainable Aquaculture and Fisheries Effort (SAFE). Now in its third phase of implementation, the program builds on the accomplishments of its initial work to further accelerate economic growth in Mindanao and help assure that as many people as possible benefit from it. As part of the former combatant reintegration assistance program, GEM provides assistance to communities to help residents to produce and sell higher value products. The farmers are diversifying from traditional crops such as seaweeds, corn, and rice, into the production of fruits, vegetables, and high-value groupers, including humpback *Cromileptes altivelis*, tiger *Epinephelus fuscoguttatus* and green grouper *E. coioides*.

The Department of Agriculture - Bureau of Fisheries and Aquatic Resources (DA-BFAR) Mariculture Park in Tawi-Tawi comprises some 500 cages for aquaculture of high value marine fish and abalone. Nationwide, 60 mariculture parks tap the potential of aquaculture of high value fish, molluscs and seaweed. Conceptualised in 2001, the government provides the basic infrastructure for 'locators' within

these parks. Park locators then were predominantly into low-value milkfish (*Chanos chanos*) for the domestic market. When GEM's SAFE introduced high-value aquaculture of groupers, especially in far-flung island provinces in Mindanao where the coastal areas are more suited for reef fish species, farmers gradually followed suit. In Tawi-Tawi, the mariculture park is almost exclusively into high-value fish culture, and BFAR says that farmers earn as much as PHP100,000/month producing high value fish and other marine products.

"The success of the GEM project is evident with the increase in Mindanao's annual export of high value grouper from a mere 33 tonnes in 2007 to over 330 tonnes in 2010, of which more than 100 tonnes were farmed by around 2,000 participants from all over Mindanao, and these have been exported live to markets in Korea and Hong Kong with a value of an estimated USD1 million (in 2010). The project is also attracting interest from several others in the aquaculture of high value fin fish. The juveniles have been procured from hatcheries. The project does not encourage the culture of fish using wild caught juveniles of reef fishes. The fingerlings have to come from a few existing grouper hatcheries in Mindanao, such as Alsons Aquaculture Corporation, which, unfortunately, only produces green grouper aside from its



*GEM technician with a brood stock for the Tawi-Tawi hatchery*



*Horaida Malik and Kumander Akbari Samson of MNLF co-op*



Jointly marketing various groupers, pompano and other seafood products to the China market at the Philippines Pavilion, during the China Seafood and Fisheries Exhibition in Dalian, China, November 2-4, 2010, Lauro Tito C. Ilagan, GEM (right) with (from left) Jonathan See, Well-Delight Network Corp., Henry Morales, Blue Seafood Exports and Carina Ong, Fishta Seafoods Division, Santeh Feeds

primary species, milkfish, and cannot keep up with the increasing demand for fingerlings,” said Lauro Tito C. Ilagan, senior aquaculture specialist, GEM.

“We will further overcome the seed supply problem in Tawi-Tawi Province with the set-up of a multispecies hatchery by DA-BFAR. This will benefit all farmers and in particular the 1,000 MNLF former combatants, who will be the initial customers for the fingerlings bred in the hatchery. The facility is already producing abalone juveniles and will soon likewise commercially produce fingerlings of both tiger and green grouper species. There is also interest to culture coral trout *Plectropomus leopardus* as soon as a hatchery in Palawan is successful in its breeding program.”

One such example of a successful enterprise that benefitted from GEM assistance is a cooperative of former combatants that operated one cage at the Tawi-Tawi Mariculture Park. It harvested its first batch of commercial groupers in 2010, with a total of 250 kg of tiger groupers, and generated net revenues of about USD 1,500. The revenue gained from this first harvest demonstrated the success of the operation and motivated the co-op to expand production to about 12 fish cages.

In 2011, when the cages are fully operational, the anticipated yearly harvest will approach 10 tonnes and will generate net revenues of USD 40,000 to 60,000 depending on production efficiencies and market prices at the time of the sales. This additional revenue will have a tightly focused and major economic impact on the families of co-op members/producers ([www.mindanao.org](http://www.mindanao.org)).



The hatchery at Tawi Tawi

GLOBALG.A.P.

## TOUR2011 Good Agricultural Practice

New Delhi | Mexico City | Cape Town | Sao Paulo | Cairo | Warsaw | Atlanta | Bangkok



### Coming Your Way

Everything you need to know about Good Agricultural Practice Certification at a place near you!

Come and join the GLOBALG.A.P. team to share latest tools and developments in Good Agricultural Practice implementation. This unique learning and networking event will be especially targeted to the issues of importance in your region!

2011 is the year where the fourth version of the Integrated Farm Assurance Standard becomes effective. This version has many enhanced features, regarding traceability, pesticide use, IPM, water use, and produce microbiological food safety. We look forward to seeing you on a TOUR 2011 stop near you!

Register now on [www.tour2011.org](http://www.tour2011.org)

Meet us in one of the following cities:

- **New Delhi** – India, 1/2 March 2011
- **Mexico City** – Mexico, 11/12 April 2011
- **Cape Town** – South Africa, 11/12 May 2011
- **Sao Paulo** – Brazil, 6/7 June 2011
- **Cairo** – Egypt, 12/13 July 2011
- **Warsaw** – Poland, 14/15 September 2011
- **Atlanta** – USA, 17/18 October 2011
- **Bangkok** – Thailand, 22/23 November 2011

Would you like to know more about the GLOBALG.A.P. TOUR 2011? Then please see [www.tour2011.org](http://www.tour2011.org) or contact Nina Kretschmer: [kretschmer@globalgap.org](mailto:kretschmer@globalgap.org) Follow us on Twitter@GLOBALGAP!

**GLOBALG.A.P.**  
The Global Partnership for Good Agricultural Practice

# Deformities in tiger grouper culture in India

By Y.C. Thampi Samraj, P. Jayagopal, D. Thinesh Santhar, P.N. Damodar and Michael A. Rimmer

The role of the Rajiv Gandhi Centre for Aquaculture (RGCA) is to develop new aquaculture technologies for the production of high value marine finfish and shellfish incorporating sustainable aquaculture practices. RGCA is an organisation established by the Marine Products Export Development Authority (MPEDA), Ministry of Commerce and Industries, Government of India. The project to introduce aquaculture production technology for groupers to India is based in the Andaman and Nicobar Islands where RGCA has leased an existing commercial hatchery. The hatchery has been substantially modified from its original configuration to make it suitable for grouper production.

The sea cages were set up near Rutland Island, South Andaman, in April 2006 to hold brood stock of tiger grouper (*Epinephelus fuscoguttatus*), squaretail coral grouper (*Plectropomus areolatus*), green grouper (*E. coioides*) and mouse grouper (*Cromileptes altivelis*). However, only brood stock of the first two species are readily available in Andaman Islands.

A population of tiger grouper brood stock was established, and these began spawning in July 2007. Tiger grouper in the sea cages spawn for 8–9 months of the year. Spawning occurs for 3–4 days in association with the new moon and each spawning event produces between 2 and 40 million eggs.

## Morphological deformities

The RGCA hatchery has successfully produced tiger grouper fingerlings for trial grow-out in sea cages. However, a noticeable proportion of fish from all production 'runs' have had some level of morphological deformity (Figure 1); this is a common problem with the tiger grouper produced in hatcheries. Several other species of *Epinephelus* reared in hatcheries have been reported to show varying proportions of deformed fish and deformities in head and jaw region are relatively common (Song et al. 2005, Nagano et al. 2007, Boglione et al. 2009, Russo et al. in press).

Deformities in the tiger grouper include antero-dorsal flexure of the head, twisted jaws, and missing or deformed opercular bones.

The deformities may be visible at small sizes (i.e. 1–2g body weight) but less severe deformities may not be apparent until the fish reach 150g. The incidence of deformities in tiger grouper ranged from 12% to 38% in 4 batches of tiger grouper. By comparison, Song et al. (2005) reported the incidence of deformities in hatchery-reared *E. bruneus* to be up to 50%, and Nagano et al. (2007) reported an incidence of 98% deformed larvae in one tank of *E. septemfasciatus*.

## Slower growth

We observed that deformed tiger grouper had difficulty in feeding. They had difficulty in ingesting and retaining pellets and often would eat very few pellets before ceasing to feed. Due to this differential response to feeding, deformed fish were moved to a separate cage where they did not need to compete with the normal fish. However, growth rate of deformed fish continued to be much lower than that of normal fish (Figure 2).

## Poor health and higher mortality rates

Another observation was that deformed tiger grouper had overall poorer health and higher mortality rates than normal grouper. We estimate that around 70% of total mortalities were deformed fish, despite them being a much smaller proportion of the population.

Figure 1. Common types of deformities in tiger grouper.



Antero-dorsal flexure of the head



Twisted jaws



Deformed opercula



Deformed jaws

**Figure 2. Example of growth disparity between normal and deformed tiger grouper held in sea cages at Andaman Islands, India.**

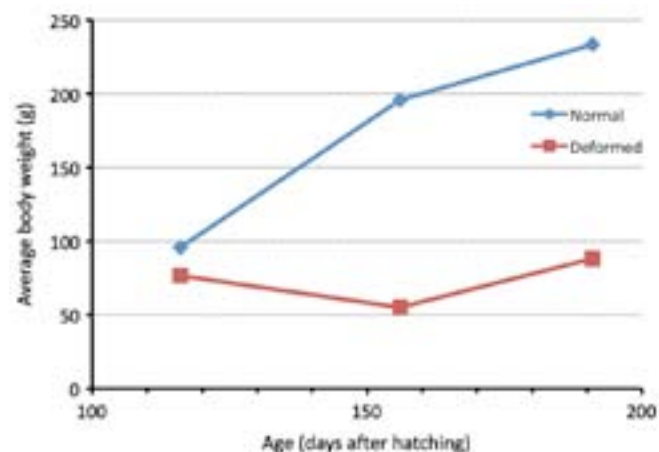

Additionally, deformed fish, because of their poor health status, may act as reservoirs of parasites and may thus present a biosecurity threat to the whole population.

### Implications for tiger grouper culture

Deformed tiger grouper demonstrate slow growth and high mortality rates compared with normal fish and as such we recommend that they are culled from the population as soon as the deformities become apparent. The costs of maintaining deformed fish cannot be recovered; most likely they will die before harvest or take several years to reach marketable size. In many cases, deformed fish are not marketable and may be rejected by the buyer or purchased at a lower price.

The cause of deformities in hatchery-reared tiger grouper has not been established. A range of causes for deformities in larval and juvenile fish have been proposed, including nutritional, environmental and genetic aspects (Cahu et al. 2003, Nagano et al. 2007). Boglione et al. (2009) found that the incidence of deformities in *E. marginatus* increased with increasing larval density, and Russo et al. (in press) found skeletal anomalies to be related to the rearing process used. Further research is necessary to reduce the proportion of deformed tiger grouper in hatchery-reared populations, in order to improve the overall economic performance of tiger grouper culture.

*The article is based on a presentation titled 'Growth and survival of deformed tiger grouper Epinephelus fuscoguttatus in Andaman & Nicobar Islands, India' at the Asian Pacific Aquaculture 2011, Kochi, India, 17-21 January 2011.*

### Acknowledgments

Sincere thanks to Ms. Leena Nair IAS (Chairman MPEDA and President RGCA) for constant encouragement and support for this project. We are also thankful to Shri. G. Mohan Kumar IAS (former Chairman, MPEDA) for initiating this project. We thank the Network of Aquaculture Centres in Asia-Pacific (NACA) and Integrated Services for Development of Aquaculture and fisheries (ISDA), Philippines, for their technical support to the project. We also thank the Andaman and Nicobar Islands administration for their support and cooperation.

### References

Boglione, C., Marino, G., Giganti, M., Longobardi, A., De Marzi, P. and Cataudella, S. (2009). Skeletal anomalies in dusky grouper *Epinephelus marginatus* (Lowe 1834) juveniles reared with different methodologies and larval densities. *Aquaculture* 291, 48-60.



Cahu, C., Zambonino Infante, J.L. and Takeuchi, T. (2003). Nutritional components affecting skeletal development in fish larvae. *Aquaculture* 227, 245-258.

Nagano, N., Hozawa, A., Fujiki, W., Yamada, T., Miyaki, K., Sakakura, Y. and Hagiwara, A. (2007). Skeletal development and deformities in cultured larval and juvenile seven-band grouper, *Epinephelus septemfasciatus* (Thunberg). *Aquaculture Research* 38, 121-130.

Russo, T., Scardi, M., Boglione, C. and Cataudella, S. (in press). Application of the Self-Organizing Map to the study of skeletal anomalies in aquaculture: the case of dusky grouper (*Epinephelus marginatus* Lowe, 1834) juveniles reared under different rearing conditions. *Aquaculture*.

Song, Y.B., Oh, S.R., Seo, J.P., Ji, B.G., Lim, B.S., Lee, Y.D. and Kim, H.B. (2005). Larval development and rearing of longtooth grouper *Epinephelus bruneus* in Jeju Island, Korea. *Journal of the World Aquaculture Society* 36, 209-216.



Y.C. Thampi Samraj



P. Jayagopal



D. Thinesh Santhar



Dr Michael A. Rimmer



P.N. Damodar

Y.C. Thampi Samraj is Project Director, RGCA based in Sirkali Taluk, Nagapattinam District, Tamilnadu. Email: rgcaho@gmail.com

P. Jayagopal is Project Manager, domestication of tiger shrimp & grouper project based in South Andaman. Email: dtsp@rediffmail.com

D. Thinesh Santhar is Assistant Project Manager, grouper project in Kodyaghat, Andaman & Nicobar Islands. Email: rgcagp@rediffmail.com

P.N. Damodar is Assistant Technical Manager, South Andaman.

Dr Michael A. Rimmer is a consultant to the RGCA grouper project. Email: aceh\_arp@iprimus.com.au

# The superior all male tilapia from China

The superior strain of tilapia, marketed by Luye Fisheries is the result of the work by Professors Zhang Hai Ming and Yang Yong Quan. Their 16-year family-based and directional selection has resulted in a fast growing and high flesh yield tilapia. The morphological traits are small head, high back and thick body.

In the last ten years, they have focussed on a sex control study, and have selected 400,000 pieces of super male parents whose sex gene is YY type. These were used to cross with XX sex gene type Nile tilapia, and the result can be 97-98% male population—superior all male tilapia. The attributes of the all male tilapia are listed as fast growing, high disease resistance, high cold resistance and absolutely hormone free.

## Fast growth

“There is no obvious advantage in the growth trait of fish below the 400g size. However, above 400g, the growth is faster than conventional strains and this is an advantage when we need to grow tilapia to over one kg size. Field data from farmers showed that fish fry of one cm size stocked at 2,000 pcs/mu (3,000/ha) in ponds reached 300-350g in 4 months and 10 days and over 500g size with aeration. In comparison, a farmer with similar skills in culturing tilapia but using other strains of fish will show growth of tilapia to only 200-300g within the same period,” said Liu Detong, who was marketing the tilapia fry and displaying brood stock at the China Fisheries and Seafood Exhibition in Dalian in November, 2010.

Other field data indicated the following size distribution. When 2-3 cm fish are stocked at 1,700 pcs/mu (2550/ha), the growth performance after 4 months and 10 days was 37% of the stock at more than 500g and 63% at 400-450g. At 5 months and 10 days, the growth was 20% at 800g or more and 80% at 650g size or more. The company will also carry out culture in cages and collect field data.

## Highest fillet yield

According to Liu, their hybrid has the highest fillet in the industry in China at 39%, making it the ideal fish for fillet processing. Additionally, the high disease resistance of the tilapia has evolved with the selection process. “This was tested when there was a large scale *Streptococcus* infection in 2009 and 2010. The loss to the farms using our YY tilapia was the smallest. The high cold resistance was also tested during the three cold spells in 2008, 2009 and 2010.

“This is our best advantage for the super males as far as tilapia culture in China is concerned. Remember how China’s tilapia output



Liu Detong holds a YY brood stock at the Luye Fisheries booth

was adversely affected during those cold spells? However, the YY super males eat well at 13°C with sunlight but without sunlight, even at 14°C, feed intake is lowered.”

Luye Fisheries distributes its tilapia fry from three bases in Guangdong, Fujian and Hainan provinces. Production is 400 million tilapia fry yearly, accounting for 14% of China’s tilapia fry market. Xiamen Luye Fisheries is the national base for breeding tilapia where new breed development and YY breeding selection is done ; while the Guangdong and Hainan Luye Fisheries bases are mainly producing the YY super male tilapia and red tilapia. Hainan Luye Fisheries has the advantage of a warmer climate and can produce tilapia fry one or two months earlier than other provinces in China.

# NEXT ISSUE

**May/June 2011** issue will feature

- Responsible & Sustainable Aquaculture
- Catfish
- Additives & Feed enzymes/ Lipid nutrition

**Bonus distribution:**

- *Vietfish International 28-30 June, Ho Chi Minh City, Vietnam*

**Deadlines:** Technical articles – April 4, 2011

Advert bookings – April 8, 2011

Contact information: Email: [zuridah@aquasiapac.com](mailto:zuridah@aquasiapac.com) ; [enquiries@aquasiapac.com](mailto:enquiries@aquasiapac.com)



## New specialised juvenile feed range for tropical fish

Between the hatchery and the grow-out farm, fish go through a very sensitive period: the juvenile phase. To support fish in this specific phase, the Ocialis research team has developed a specific feeding program for juvenile fish called Nanolis. Nanolis is a specialised juvenile range of feeds for tropical fish. The difficulties during such periods are that fish needs small particles (from 0.6 to 1.5 mm). They are also very demanding with regard to palatability and digestibility and their fragility makes them very sensitive to stress and pathogen attacks.

The advantage of Nanolis over crumbles- the most common way to produce starter feeds, is the prevention of leaching and the high palatability of the Nanolis feed. The Nano extrusion process gives a perfect feed stability whilst preserving its nutrition. The feeds also contain specific nutrients to enhance fish health and uses selected digestible raw materials adapted to the fragile digestive system of the fish. These starter feeds are designed for intensive culture conditions. Ocialis presented this innovation at Aquatic Asia 2011 held in Bangkok from March 9-11.

More information: [www.ocialis.com](http://www.ocialis.com)



## Hainan's new tilapia feed mill

Hainan Yubao Highest Quality Aquaculture Feed Co, is wholly owned by Seattle-based HQ Sustainable Maritime Industries Inc., a major tilapia integrator on the island. The feed mill is located in Wenchang City, the heartland of tilapia production in Hainan. It was set up at a cost of USD 15 million. Hainan Island is one of China's major producers of tilapia, and in 2009, it produced 88,000 tonnes of tilapia.

HQ has five wholly owned subsidiaries involving in processing, fry and genetics, feed production, health products and marketing. The processing capacity is 40,000 tonnes/year and the focus is on prepared foods for gourmet markets. Tilapia is produced by grow-out farms which are third party cooperative farms. Fish are fed 100% vegetarian feeds with omega 3 fatty acid from algae. Tilapia by-products also go into the production of health products. HQ also has a hatchery for fry production and to carry out genetic studies on tilapia.

The feed mill is expected to produce 100,000 tonnes of tilapia feed comprising 70,000 tonnes of sinking and 30,000 tonnes of floating pellets. The 'tiloveya' brand of feed is extruded as well as pelleted and contains 28-39% protein. The feed mill has a strategic partnership with nutritionists and feed production experts from Hainan University, Zhongshan University in Guangdong and other universities. There are already several feed mills on Hainan Island supplying farms, but Norbert Sporns, CEO of HQ Sustainable Maritime, said the push factor for the company to have its own feed mill is because the control on quality production starts with the feed.

"Increasingly, we have third party certifications embracing the total integrated delivery of quality solutions. High end tilapia products require specialty feeds. As an industry leader this was the only way to go. There is also the uniqueness of the feed as compared to commercial feeds in the market. We have formulated in high levels of unsaturated fatty acids (DHA and EPA)."

The production will not be limited to tilapia feeds. Sporns said, "In the future, we will add another line and start to produce more specific feeds for other aquaculture species. Of the 100,000 tonnes capacity, we expect to use about two thirds for our farmers and the rest will be sold in the open market. Aside from feeds, the company has a hatchery and provides advice on farming techniques.

"Our feed production is at a lower cost since we view ourselves as more efficient. Currently we have one extrusion line. We use Buhler equipment since, in this way, we are able to get the best efficiency in production. We view Buhler as a leader in the industry."



Norbert Sporns

# EWOS in Asia with Vietnam JSC

This will be the first major move into Asia for the company and there is a lot of interest amongst fish buyers, farmers and investors in what the company can bring to Vietnam.



At the signing ceremony, from left, Philippe Serene, Rune Vamraak, Dr Einar Wathne, Nguyen Hieu Liem, the future Chairman of EWOS Vietnam and David Serene.

In January, Cermaq AS (Norway) and ANOVA Corporation (Vietnam) held a ceremony to formally sign the contracts which will allow the creation of EWOS Vietnam JSC. This will be done through the acquisition of shares from Anova Corporation and a further share issue, allowing Cermaq to hold 51% of the newly formed joint venture company. The total investment will be close to USD6 million. Dr Einar Wathne represented the Norwegian company, Nguyen Hieu Liem and David Serene were present for Anova Corporation and Philippe Serene for Tohu Bohu, the third party in the joint venture.

Cermaq is a Norwegian company, listed on the Oslo stock exchange. It is the parent company of EWOS AS, a world leader in aquaculture feed production, with a focus on salmon feed, but with experience in producing feeds for over 20 fish species. EWOS is a research and development driven company, with its own research stations utilising an annual budget of USD16 million.

## Focus on pangasius

This JSC will utilise the existing Anova Aquafeed factory in Long An Province, with an estimated annual capacity of 85,000 tpy. Support from the joint venture partners will allow this to be expanded within 5 years to become one of the leading players in the Vietnamese aqua feed market.

The focus of production will be on the pangasius market. In recent years, the annual production is around 1.8 million tonnes of pangasius catfish. However, farmers have not been able to achieve good production results economically whilst foreign criticism of the farming methods has also increased. The joint venture partners believe that Vietnam has an excellent opportunity for high quality aquaculture in the future, but that there needs to be a focus on product quality control and safety. In turn, this will help justify higher export prices

for all products. The situation often seen of producing commodity fish, traded at the lowest prices in order to attract customers, should not continue for the important markets.

It is the aim of the JSC to support the farmers' goal to reduce the cost of production of high value fish, which will attract sales in Europe and the USA. This will be done through a combination of R&D of the feeds and improved process control in the factory driven by EWOS. The Norwegian partner is also expected to bring expertise in factory production systems and food safety systems to the joint venture, ensuring high quality feeds and supporting customer demands for safety. An early goal is to launch feeds which will reduce the amount of feed required to grow the fish and increase the growth rate, as well as to investigate production standards such as the much promoted GlobalGap, BAP and ASC standards.

The general director of the new company will be Rune Vamraak, who has moved from his position of supply chain director of EWOS in Norway. He will be supported in his role by Philippe Serene, previously general manager of Proconco, who will act as an advisor. Much of the current ANOVA Aquafeed positions will remain, as there is a young and enthusiastic team in place. However, a new technical department will be created, led by Dr Dave Robb (the representative officer of EWOS in Vietnam for the last 2 years). This will steer the R&D and QA/QC programs with the goal of developing new products and ensuring feed quality and safety to a standard demanded by the high value markets.

In February, there will be the handover of company operations. After a long period of market research into the Vietnamese aquaculture industry, the company is eager to start operations and bring their ideas and expertise to the country.

# New company brand

**The former DSM logo – the blue hexagon represented the strength, proud history and dependability of DSM. The company has entered a new era and this is the time to mark the new DSM by adopting a new brand.**



Over recent years DSM has changed from being a predominantly 'chemicals' company to being a leading Life Sciences and Materials Sciences company active in health, nutrition and materials. The new brand is a logical step as the company is now entering a new era of focused and innovation-driven growth.

To respond to the big global challenges of climate and energy, health and wellness and global shifts, the company is becoming even more externally focused, demonstrating greater accountability for performance and placing greater emphasis on collaboration and speed of execution. In all of this it is guided by their core value- sustainability, and by the belief in diversity, including internationalisation.

"DSM has launched a new company brand. An important difference compared with the past is that in future, the only DSM brand you will see besides our product brands is our overall company brand. This is a logical next step in our transformation as it confirms to all our stakeholders, most importantly, to our customers, the changes that have already taken place and articulates our excitement about, and aspirations for, the future," said Karim Kurmaly, vice president, DSM Nutritional Products, Animal Nutrition & Health Asia Pacific & Indian Continent.

"The new identity is more than a statement of purpose and the value it brings to customers. It will also give a better idea of (and therefore easier access to) the full breadth of skills, competences and expertise.

"We believe that by looking through the lens of Bright Science. Brighter Living.™ we will help create shared value for and with our customers. It is about developing an in-depth and sophisticated understanding of the challenges and opportunities you face, and working in close collaboration to create value for you and the customers you serve."

Sustainability is absolutely fundamental to DSM – it is the core value. That is why, as a recognised leader in sustainability, the purpose is to work with customers to develop products and processes that help them respond to the challenges of climate change, energy and resource use.

Innovation is the vehicle to enable sustainability, performance and value creation. DSM draws on the Bright Science and by adopting an open and collaborative approach to innovation, and continuing the internationalisation of its business. More information: [www.dsm.com](http://www.dsm.com).

# First animal nutrition & health plant in India

**DSM has opened its first animal nutrition and health premix plant in India. The new facility allows the company to directly provide high quality products as well as innovative solutions and concepts to its customers in the Indian subcontinent.**

This enables DSM to capitalise on opportunities that arise from rapidly developing animal nutrition & health industries in one of the world's key growth countries. India is emerging as a major livestock production centre. It currently ranks 5th as a broiler producer as well as the world's 4th largest egg producer.

The new DSM plant is located in Ambarnath, Mumbai. It will provide high quality, fully traceable, innovative and sustainably produced feed premixes under the brand name Rovimix®.

"As a very important link in the food chain, feed premixes for animal nutrition and health are of great importance for ensuring food safety and nutrition to all. This investment is fully in line with our strategy which, among others, aims at sustainable development in the high growth economies. Targeting India's large market, we continue to strengthen our footprint and support the country in accelerating the development of its animal nutrition & health industry with new technologies and products," said the president Animal Nutrition & Health, Antonio-Ruy Freire.

"As the global leader in animal nutrition and health, we are committed to provide safe and high quality innovative products for our customers, ensuring the provision of the food chain with fully traceable feed premixes. Our premixes are produced according to the Optimum

Vitamin Nutrition (OVN®) standard, and they include as well DSM innovations such as, for example, Ronozyme® Phytase contributing to environmental protection, Ronozyme®ProAct supporting feed cost reduction and enhancing nutrient utilization, Rovimix® Beta-carotene for improved dairy productivity or Rovimix® Hy-D® for improved poultry performance. These innovations are specifically designed to support our customers in India," vice-president Asia Pacific Animal Nutrition & Health, Karim Kurmaly, said at the official opening.

"The animal nutrition & health industry in India is growing, and it is a privilege for DSM to be part of this development. The investment is the first of many for DSM in the nutrition sector in India. With this first venture of DSM Nutritional Products in our country, we begin to implement a future-oriented strategy in a key strategic market," adds president DSM India, Rajiv Chopra.

DSM Nutritional Products is the world's leading supplier of vitamins, carotenoids and other fine chemicals to the feed, food, pharmaceutical and personal care industries. The business has sales of over EUR 2 billion and a long tradition as a pioneer in the discovery of new products, formulations and attractive applications for manifold industry segments.

More information: [www.dsmnutritionalproducts.com](http://www.dsmnutritionalproducts.com)



Nutrition, health, performance ...naturally

## Game-changing strategies in 2011

The pursuit at Alltech's 27th Annual International Animal Health and Nutrition Symposium will be 'exploring *The Game Changers* for the animal health and feed industries'. The symposium will be held from May 22-25, 2011 in Lexington, Kentucky.

Dr. Pearse Lyons, president and founder of Alltech says, "Today's challenges signal that it's time to rewrite the playbook. Raw materials are becoming rare materials. Least-cost rations are but one example of failed strategy. Sustainability is questionable with conventional practices, and consumer confidence is tepid at best."

Alltech's 2011 international symposium will be an industry time-out, providing opportunities for professionals to huddle in specialised breakout sessions; aquaculture, beef, dairy, equine, poultry, pig production, pet food, regulatory, food quality, traceability and communication in agriculture. All sessions will be dedicated to the open discussion of

creative game-changing strategies for revolutionising industry practices and thus redefining its future. Plenary and breakout sessions will include focussed discussion on programmed nutrition; technology to maximise release of nutrients from DDGs and other feedstuffs; formulation to minimise nutrient waste; branding nutrition; sustainability strategies; and the use of new media in communicating directly with the consumer.

The prestigious Medal of Excellence and Alltech Young Scientist Awards will also be presented during the symposium. More information, including a full agenda with topics and speakers, and to register; [www.alltech.com/symposium](http://www.alltech.com/symposium)

### The Game Changers for Aquaculture

- **The Blue Revolution: The role of solid-state fermentation enzymes** by S. Corneillie, Alltech, Tokyo, Japan
- **Writing the next chapter in fish consumption: Predictions for a sustainable aquaculture feed industry** by G. Allan, Port Stephens Fisheries Institute, New South Wales, Australia
- **Redefining zinc in aquaculture feed: The Plymouth project** by D. Leeming, University of Plymouth, Devon, UK
- **The Game Changers: The case of Chiloé, ISA; the past, present and future of the salmon industry** by J. Duval, Cultivos Marinos Chiloe S.A., Chile
- **Responding to the sea lice challenge: Can Aquate® modulate mucus production in fish?** By K. Pittman, University of Bergen, Bergen, Norway
- **Fifteen years of Bio-Mos®: Is fish production the next frontier?** By T. Reveco, Marine Harvest Chile, Puerto Montt, Chile
- **Gut health — New strategies for disease defense** by P. Spring, Swiss College of Agriculture, Zollikofen, Switzerland
- **A disruptive technology: The role of zinc in wound healing** by J. Sweetman, Cephalonia, Greece
- **Shrimp production at the crossroads: Are there alternatives to fishmeal?** By V. Suresh, Integrated Aquaculture International, Brunei Darussalam
- **The Aquaculture Agenda: Producing high-quality products with the least environmental impact** by D. Griffith, C. I. Cartagena de Acuacultura, Cartagena, Colombia
- **Nutritional solutions to ingredient shortages - The potential for algae** by S. Davies, University of Plymouth, Devon, UK

## OMRI lists Sel-Plex 1000

Since 1993, Sel-Plex 1000 has been a standard organic selenium source in animal diets around the world. With Organic Materials Review Institute (OMRI) listing, Sel-Plex 1000 (Alltech, USA) can be readily included in all organic feeding programs across the US and is approved for use in organic farming. This approval makes Sel-Plex 1000 the third product the company has listed with OMRI.

"Alltech is committed to registration and upholding regulatory values in markets around the world," said Steve Traylor, Global Director of Regulatory Affairs. "With a dedicated focus to standard and specialized regulatory issues, Alltech can offer our customers the piece of mind that they can confidently use a product that is not only well researched, but one that has gone through the proper channels and declared safe for sale. We offer high quality, traceable solutions that can be incorporated in a variety of feeding programs."

"Selenium is an essential nutrient for both animals and people, and plays a critical role in metabolism, normal growth, reproductive

health, and immunity," said Alltech president and founder, Dr. Pearse Lyons. "Because of its specific organic form, Sel-Plex selenium is better absorbed and retained by the animal. Sel-Plex provides selenium in nature's form — the safest form."

Sel-Plex is also the only FDA reviewed form of organic selenium, and is the first strain specific form of organic selenium to be EU approved for all species (Strain: *Saccharomyces cerevisiae* CNCM I-3060). More information: [www.alltech.com](http://www.alltech.com)

## Cuts the ribbon on opportunity at algae facility

**Alltech Algae is a state-of-the-art algae fermentation facility that was acquired in 2010 from Martek Bioscience Corporation for approximately USD14 million and has been renovated in the past few months to begin in April as one of the largest algae production sites in the world.**

A ribbon cutting ceremony at the USD200 million plant in Winchester, Kentucky in February was attended by local and state government officials as well as the 60 global attendees of the first Annual Algae Conference hosted by Alltech in Lexington, Kentucky.

“For Alltech, algae fermentation presents the latest technological frontier from which we expect incredible opportunities in the areas of food, feed and fuel to arise,” said Dr. Pearse Lyons, founder and president of Alltech, a global leader in natural animal nutrition. “We have already been working in this area for several years and see it playing a major role in both human and animal health and nutrition.

“I am confident that this will be one of the key pieces that will help our company pass the USD one billion revenue threshold in 2015,” Dr. Lyons continued.

“The community of Winchester and Clark County are pleased to welcome Dr. Pearse Lyons, a world class innovator and business leader, and his company, Alltech, to join our business and corporate community,” said Ed Burtner, mayor of Winchester. “We are excited that Dr. Lyons has chosen Clark County as the location to launch the next generation of biomass uses at his algae production facility in Winchester. This will allow Alltech to become a world leader in algae production which will serve as the platform for a host of biomass uses in the years to come.”

The primary focus of the facility will be the development of products derived from algae. The algae will be used for value-added feed products, algae-derived bio-fuel and the production of ethanol.



*President of Alltech, Dr. Pearse Lyons cuts the ribbon at Alltech Algae in Winchester alongside his wife Deirdre (centre), (from left) Judge Executive Branham, Mayor Burtner, Secretary Hayes, and Alltech's CFO Nathan Hohman.*

## Nutreco to acquire fish and shrimp feed company in China

The global leader in animal nutrition and fish feed, announced in February that it has agreed to acquire fish and shrimp feed company, Shihai Co Ltd located in the Pearl River Delta, Guangdong Province. The feed mill has about 5% of the high end fish feed market in south China and has shown an annual growth rate of 23% in the last five years. Shihai Co produced approximately 100,000 tonnes of fish and shrimp feed in 2010. In 2009, it commissioned a new feed plant with a capacity of approximately 150,000 tonnes. The new plant is constructed and equipped to a high standard and is capable of operating to Skretting specifications.

This acquisition valued at EUR 40 million will provide Skretting, Nutreco's aqua feed business, with a production base in China, the world's number 1 aqua feed market. The fish feed market is estimated at 8.6 million tonnes. It is also fully in line with the strategy to capitalise on Nutreco's leading fish feed positions and diversify by expanding in new regions and into feed for other species and shrimp. The closing of the transaction is subject to permission being granted by the authorities in China. With the completion of the acquisition, Skretting continues growing the business, supplying fish feed for species such as shrimp, various marine fish species, tilapia, snakehead and catfish.

Knut Nesse, Nutreco CEO Aquaculture said, “This is an excellent strategic acquisition for Skretting. China is world's number 1 in aquaculture production and the world's largest producer of shrimp. Skretting has gained insights into the aquaculture market of China over the past four years through a toll milling operation. Feeds for shrimp, marine species and species such as tilapia are sectors where Skretting can contribute with its nutritional knowledge and manufacturing expertise. It can accelerate progress by sharing knowledge and experience through its presence for example in Vietnam and Brazil and activities at the Skretting Aquaculture Research Centre. The acquisition is a further important step in the implementation of our growth strategy.”

More information: [www.nutreco.com](http://www.nutreco.com)

# Breakthrough produces safer to eat shellfish

A new technology to make shellfish safer to eat has been pioneered by scientists at Queen's University Belfast. The new test, developed at Queen's Institute for Agri-Food and Land Use, not only ensures shellfish are free of toxins before they reach the food chain but is likely to revolutionise the global fishing industry.

While the current process for monitoring potentially dangerous toxins in shellfish takes up to two days, the new test slashes the testing time to just 30 minutes using new biosensor technology and provides a much more reliable result. The test detects paralytic shellfish poisons, which paralyse anyone who consumes them and kills around 25% people who are poisoned.

Leading the project is Professor Chris Elliott, Director of the Institute of Agri-Food and Land Use at Queen's School of Biological Sciences, who said, "Toxins secreted by algae, and which concentrate in shellfish, are a major hazard to consumers and can bring huge economic losses to the aquaculture industry.

"While the existence of these toxins has been known for some time, there have been major concerns about the effectiveness of tests used to detect them. There is also growing evidence that climate change is causing many more toxic episodes across the world, resulting in the closure of affected shellfish beds.

"The new test, developed at Queen's, is much quicker and more reliable than existing methods. It works by using unique 'detector proteins' to seek out minute amounts of toxins present in mussels, oysters, cockles and scallops.

"The test will not only make shellfish safer to eat, but it will also have a significant impact on global aquaculture industries as they struggle to deal with the rising problems of toxins caused by climate change."

The test has been developed as part of a €10 million (Euro) BioCop research project led by Queen's and involving 32 international research partners and the European Commission. The institute has also signed a contract with the UK-based company Neogen Europe to commercialise the idea.

This will be the third such aquaculture product developed by Queen's and Neogen Europe, helping the company to develop its unique portfolio of rapid food safety tests and reinforcing Queen's reputation as a global leader in this area. Research at Queen's will also be aided by a USD 500,000 grant from the American Food and Drugs Administration (FDA) to further develop the test in the USA so it can be conducted in laboratories and on boats as soon as the shellfish are caught. This will cut the time taken to get the catch from fishing nets to supermarket shelves. More information: [www.biocop.org](http://www.biocop.org)

## Appointments

# Chanin Chinrungsikul joins Diamond V Asia

Diamond V Asia has announced the addition of Chanin Chinrungsikul as manager, Asia Region Sales and Technical Support. Chinrungsikul will be responsible for promoting and supporting the continued growth of the aqua business for Diamond V in Southeast Asia. Chinrungsikul comes to Diamond V with a breadth of experience in the sales and marketing of animal feeds, nutritional supplements and premixes, along with human pharmaceuticals. Chinrungsikul earned his degree in pharmacology from the Prince of Songkhla University and a MBA from Dhurakitphundij University, Thailand. He will be based in Bangkok, Thailand. For more information, [www.diamondv.com](http://www.diamondv.com).



*Chanin Chinrungsikul*

# Novus appoints head of new South Asia region



*Dr Vaibhav Nagpal*

Well known feed industry specialist, Dr Vaibhav Nagpal has recently been appointed a sales director for the newly created World Area of South Asia for Novus Animal Nutrition (India) Pvt Ltd. He received his degree in Veterinary Sciences in 1993 from Haryana Agricultural University located at Hisar, India and then Masters in Veterinary Sciences in Microbiology (specializing in Virology) from the Indian Veterinary Research Institute, Izatnagar, India in 1996.

Dr Nagpal has more than 14 years of relevant and practical sales experience in Asia Pacific and also technical support for feed quality.

He joined Novus in September 2007 to launch the Feed Quality Division in Asia Pacific. He was predominantly working on improving the efficiency of the feed mills and feed hygiene until his recent promotion to lead the rapidly developing South Asia business. For more information, [www.novusint.com](http://www.novusint.com).



## Asia's Largest Seafood Show

# CHINA FISHERIES & SEAFOOD EXPO 2011

November 1-3, 2011  
Qingdao, China

16th Annual Show

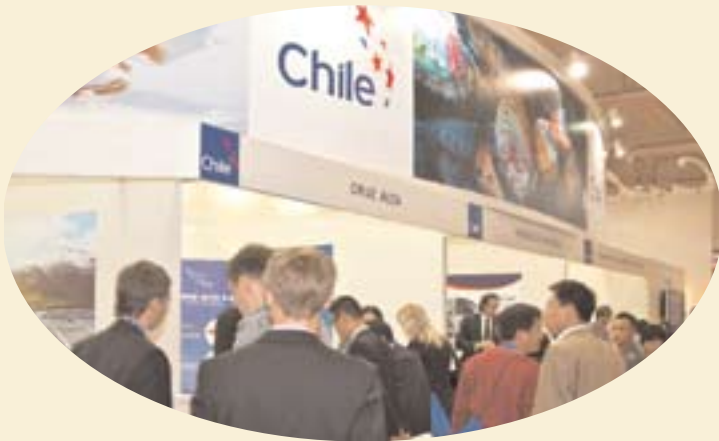

There's never been a better time to market your seafood to the world's largest - and fastest growing - seafood market.

Whether it's expensive seafood like abalone, lobster or crab, or lower value seafood like mackerel, squid or sardines, there's a market for your seafood in China. The best way to get your share of this lucrative market is to exhibit at China Fisheries & Seafood Expo. For the 15th straight year, China Fisheries & Seafood Expo, which was held in Dalian last November, set a record in the number of exhibitors and visitors. This year's show will feature almost 2,000 booths and 15,000 visitors from more than 80 countries.

### Organized By:

Sea Fare Expositions, Inc.  
2360 W. Commodore Way, Suite 210  
Seattle, WA 98199  
Tel: 206-789-5741 Fax: 206-789-0504  
E-mail: [seafoodchina@seafare.com](mailto:seafoodchina@seafare.com)

### Sea Fare China Ltd.

16 F/A No. 58 Freetown Center  
South Road Dongsanhuan  
Beijing 100022 P.R. China  
Tel: +86 10 58672620 Fax: +86 10 58672600  
E-mail: [info@seafarechina.com](mailto:info@seafarechina.com)  
[www.seafarechina.com](http://www.seafarechina.com)

[www.chinaseafoodexpo.com](http://www.chinaseafoodexpo.com)



# Asian Pacific Aquaculture 2011

Industry looked at the opportunities in shrimp, freshwater prawn and pangasius catfish aquaculture in India, whilst learning from experiences of global counterparts.

This was a landmark event for the industry in India. It was the first major aquaculture event in India and was supported by almost all government agencies involved in aquaculture. Touristic Kochi in Kerala with its backwaters, provided an excellent venue. Kochi is a major seafood processing hub and Kerala state contributes 0.7 million tonnes of aquaculture production to the national output of 7.5 million tonnes. The targets are USD 5 billion of seafood exports by 2012. Organisers in India, led by Dr Mohanakumaran Nair, Dean, Fisheries Faculty were pleased at the outcome of the event which brought the who's who in Indian aquaculture, stakeholders and farmers together. Experts and regional players discussed possible ways to further advance Indian aquaculture.

The Asian Pacific Aquaculture 2011 (APA 2011) was organised by the Asian Pacific Chapter of the World Aquaculture Society together with the Department of Fisheries, Government of Kerala. It was held at the Le Meridian Resort and Convention Centre in Kochi, India from 17-21 January 2011. The College of Fisheries was the local organiser and during the event, it was elevated to university status and is now named The Kerala University of Fisheries & Ocean Studies. This is a first for a college of fisheries in India. The Gold sponsor for the event was Novus International Inc and other sponsors were Biomin (which sponsored the nutrition session) and Muyang.

The opening was commemorated by the Minister for Fisheries & Registration, Government of Kerala, S. Sharma. However, due to the observance of mourning following the tragic deaths of pilgrims just 2 days before the opening meant that many other dignitaries were not able to attend but those that were able to, added value to the event. They included Dr K.R. Viswambharan, Vice Chancellor, Kerala Agricultural University, Leena Nair IAS, Chairman, MPEDA, Dr P Krishnaiah IAS, NFDB, B Sreekumar, Anwar Hashim, President SEAI, U K Viswanadha Raju and Thad Simons, President Novus International Inc.



*A classic touristic picture of Kochi; fisherman holding a freshwater prawn at the Chinese nets beach in Kochi*



*U.K Viswanadha Raju, Group Chairman, Ananda Group (right) with Anant Bharawaj, Novus International*

An important add-on to the conference session was Giant Prawn 2011 which focussed on developments in the aquaculture and marketing of the freshwater prawn *Macrobrachium* spp. This was organised by Michael New and Mohanakumaran Nair. The conference had more than 700 abstracts, 200 posters and 54 sessions. Participants and visitors to the conference and trade show totalled more than 1,000 from 47 countries. In addition, over 500 farmers from India attended an intensive Farmer's Day program and approximately 700 students from 5 colleges were treated to an introduction to aquaculture on the last day.

The plenary session saw presentations from experts in India and the region. **Dr S Ayyappan** presented the challenges in Asian Aquaculture. **Dr Peter Edwards**, Asian Institute of Technology, Thailand gave an overview of recent developments and future prospects in inland aquaculture. He briefly described the relevance of traditional aquaculture in today's aquaculture scenario. In linking traditional and modern aquaculture, Edwards cited some examples such as the 80:20 pond fish culture system in China. In aquaculture and alleviating poverty, he looked at the improved VAC system in Vietnam and intensive African catfish culture in Indonesia with extrapolated outputs as high as 300 tonnes/ha in small ponds.

Michael New, OBE, fulfilled his goals by organising the very successful Giant Prawn 2011 which ran alongside APA 2011 as well as promoting the charity he founded, Aquaculture without Frontiers (AwF). The charity secured a number of sponsorships at a special dinner event which saw an extraordinary performance from Ms Sobhana's Classical Dance Show.

"In order to network and absorb all the activities that WAS-APC conferences bring, you also need liberal doses of great food and engaging entertainment. The superb Indian hospitality culminated in the Presidents Reception held at The Bolgaty Palace with seafood generously donated by The Ananda Group and The Seafood Exporters Association of India," said the organising team.

The next conference and trade show for the Asia Pacific Chapter, World Aquaculture Society will be Australasian Aquaculture 2012 to be held in Melbourne, Australia from May 1-5, 2012. More information: [www.was.org](http://www.was.org) later this year.

## Giant Prawn 2011

Giant Prawn 2011 (GP2011) consisted of a three-day program of invited papers, plus a 1.5 day session of contributed papers and many posters. This event demonstrated the substantial growth of the freshwater prawn sector of aquaculture since the original meeting held in Bangkok (GP1980), which was also organised by Michael New.

During these three decades, the production of the giant river prawn, *Macrobrachium rosenbergii* expanded nearly 80-fold and several other species are now also farmed, notably the oriental river prawn *M. nipponense*, which is reared entirely in China. In total (with several countries yet to report data to FAO), nearly 437,000 tonnes of freshwater prawns were farmed in 2009. The global farm-gate value of farmed prawns in 2008 was almost USD 2.15 billion, showing that this sector is a significant component of aquaculture production, particularly in Asia where most freshwater prawns are farmed (the major producers being China, Thailand, Bangladesh, Vietnam, Taiwan, India, Myanmar, Indonesia, Malaysia and Iran).

GP2011 was well-attended and participants learnt from international experts in each field, including biology, genetics, health management, hatchery and grow-out management, post-harvest handling, processing & economics and poverty alleviation. Selected papers will be published in a special issue of the journal *Aquaculture Research* and the production of the proceedings is also contemplated.

In his presentation, New said, "The importance of the giant prawn as a sector of aquaculture is undeniable. The average unit product value of both giant river prawns and all species of freshwater prawns exceeds that for several major aquaculture commodities, including



Michael New accompanied by K.R. Salim, co-organiser from the College of Fisheries on the field trip. Picture by Janet H Brown.

Atlantic salmon and the two major species of marine shrimp (monodon and vannamei). The total quantity of freshwater prawns produced globally has reached 58% of the level of monodon production, but is still less than 19% of that of vannamei shrimp. The freshwater prawn farming sector in China is almost as valuable as tilapia production. The volume, and particularly the value, of the freshwater prawn farming sector is approaching that of one of the oldest established forms of finfish aquaculture - rainbow trout farming."

## Farm tour

Dr Janet H. Brown, Stirling University participated, in the second day's field trip to *Macrobrachium* farms passing through the backwaters of Kerala and gave us this report.

The leisurely and scenic trip from Alleppey (Alappuzha) took us to the site of the very first prawn farm in Kerala. Owner and pioneer prawn farmer Madam Achamma Kurien and her husband had set up the farm in 1995. The system they use is rice/prawns. This whole area is a traditional rice growing area of about 17,000 ha where in the recent past a reclamation scheme was set up to drain the land to remove the saline incursions and the whole area is some 2-3m below sea level. Subsidised electricity assists the farmers in keeping the area pumped out of water. This subsidy is available for



The Kuriens (centre) with participants of the farm tour. Picture by Janet H Brown.

the rice farmers but not (so far) for prawn farmers so they have to carefully coordinate the harvest with the timing of the need to pump out the rice.

Before restocking they allow the ponds to dry out until the cracks in the pond are at least 5 inches deep before refilling from the canal which at this time is pretty much fresh water. The Kuriens farm just 2.3ha of ponds and initially stock just a portion of the ponds with the post larvae from the Rosen Fisheries hatchery. The growing period starts around February until November.

An interesting outcome of the visit was Madam Kurien's experience with producing organic certified prawns. She spent 4 years on this: the first 2 years to get the certification and then operating with a certified product for 2 years. The accreditation was provided by Indocert using the Naturland standard. She gained a 20% price premium. However, she said that the cost of organic certified feed (as required) is almost 5 times as much as her home produced pelleted diet (approximately INR65/kg as compared to INR12/kg for her own diet). On top of this, the requirement for certification is twice per year, for the rice and for the harvested prawns at a cost of INR 8,000-10,000 each time. This has convinced her that this makes no sense. She decided to "stay true to herself" and still produce the organic prawns using her own diet made from organic ingredients but without the extra cost of the certification.

Security for her prawns is not a problem so far; no one can cook prawns in the vicinity without neighbours questioning where they got the prawns but she does easily sell the prawns locally and for export. They are mostly about 50-60g size. The very successful Giant Prawn 2011 culminated with this very interesting field trip which imparted information to participants.

## Farmer's day

This gathering of 500 farmers was supported by the National Fisheries Development Board (NFDB), Asian Aquaculture Network, Novus and various state agencies. Presentations in English were translated simultaneously to regional languages. The range of presentations covered shrimp and fish farming and seafood development. **Dr Farshad Shishehchian**, Blue Aqua International, Thailand started the session with problem solving in black tiger shrimp farming.

**Dr Niti Chuchird**, Kasetsart University, Thailand discussed developments in vannamei shrimp farming in Thailand, in particular the recent information on the feeding behaviour of shrimp, the use of auto feeders and new aeration systems to disperse small bubbles in addition to paddlewheels to provide more oxygenation in 2m deep ponds. On the white spot syndrome virus, Chuchird said, "If one farmer has not faced WSSV, then he is not really a shrimp farmer." Some remedies given in his presentation were nursing post larvae at 32°C for seven days before stocking in ponds to stop the replication of the virus. Since February 2010, farmers in Thailand faced the white faeces disease and the possible causes and remedy were outlined. His advice is that industry should emulate Thailand's way to control and track specific pathogen free stocks (SPF).

During the interaction session, farmers posed questions on the regulations by the Coastal Aquaculture Authority (CAA) which **Dr Baskaran Manimaran**, CAA director (technical) in the audience answered. He explained that regulations are to safeguard the environment and that the maximum stocking density is 60pl/m<sup>2</sup>. Some 24 hatcheries have been inspected and given the permit to import brood stock from the selected broodstock suppliers and to produce post larvae.

In fish farming, **Dr Kevin Fritzsimmmons**, University of Arizona, USA provided options in fish polyculture practices suitable for India whilst



Part of the biofloc group. Anil Ghanekar, Ecosure Systems (left) and Yoram Avnimelech



From left; Senthil Kumar, Society of Aquaculture Professionals, Kishnadas KJ, Dilip Sathyanathan, PT Indonusa Yudha Perwita, and S. Chandrasekar, Inve India.

**Dr Ram Bhujel**, Asian Institute of Technology, Thailand discussed tilapia culture which currently is strictly controlled and limited to selected companies in India.

A rise in health and environmental awareness has led to demands for products which are responsibly farmed. The role of GlobalGap in standards setting and certification was provided by **Valeska Weymann**.

GlobalGap is a private sector body that sets voluntary standards for the certification of production processes of agricultural (including aquaculture) products around the globe. The set of standards serves as a practical manual for Good Agricultural Practice (GAP) and is designed to assure consumers on food safety, animal welfare, minimization of environmental impacts of farming operations and a responsible approach to worker health and safety. She introduced version 4 of the GlobalGap Integrated Farm Assurance Standard for Aquaculture which was started in January 2011. This version will allow certification of all products of aquaculture origin (including hatchery based, with the consideration of passive collection of seedlings in the planktonic phase). This innovative approach is aimed to reduce the complexity and cost of farm certification. In March 2010, the compound feed manufacturing standard was started and farms have a reliable tool when it comes to feed safety of compound feed used. Details will be provided in an article in issue 3, May/June 2011).

## Biofloc technology updates

In this half-day session, several presentations covered the developments in the use of biofloc technology (BFT) in farming marine shrimp, tilapia and *Macrobrachium rosenbergii*. The session chair **Professor Yoram Avnimelech**, Israel said that BFT in tilapia production is becoming common in tropical and temperate regions. The fish is well adapted to biofloc technology since it excels in filtering out the bioflocs from the water and is adapted to growing in high density systems. An important difference between shrimp BFT systems and tilapia systems is the biomass used. In BFT shrimp production systems, the biomass can reach up to 2 kg/m<sup>3</sup> whereas the common fish density in BFT tilapia systems is 10 times higher. A biomass of 20-30 kg/m<sup>2</sup> is practical, demanding an aeration of about 150 hp/ha.

In the farming of the vannamei shrimp, **Dr Nyan Taw**, Malaysia said that for commercial culture, the basic requirements for the system include high stocking density with 130-150 PL10/m<sup>2</sup> and high aeration of 28 to 32 hp/ha with correct paddlewheel position in ponds. Ponds need to be lined with concrete or high density polyethylene (HDPE), and pelleted grain and molasses are added to the culture water. Shrimp production of 20-25 tonnes/ha/crop with FCR of as low as 1:1 are normal for biofloc systems. A maximum production of nearly 50 tonnes/ha was achieved in small ponds in Indonesia. The system has spread to Indonesia (from Medan to Lampung, East Java and Bali), China and Malaysia. South and Central American countries are also interested in the system.

## Novus celebrates 20 years

The Gold Sponsor of this event, Novus International had a cake cutting ceremony as it began to celebrate the company's milestones throughout 2011 at APA 2011. There was also a customer appreciation dinner for more than 120 clients and customers. The theme for the 20th anniversary of Novus International, Inc. was 'innovation with integrity.'

"Innovation with Integrity' has been a central attribute of Novus' culture from the beginning. Our heritage has been built on developing innovative, science-based health through nutrition products for livestock, pets and people," explained Thad Simons, president and CEO of Novus. "We are very proud of our global network of employees, customers and partnerships and excited to embark on a year of celebration with the many people who support our continued growth and success."

*Thad Simons at the Novus booth.*



## Trade at Asian Pacific Aquaculture 2011

Most of the exhibitors at the 60-booth trade show were companies and government research institutions in India. The National Bureau of Fish Genetics distributed guidelines for the import and culture of tilapia and on the culture and breeding of vannamei shrimp. The range of products by international and Indian companies were in feeds and feed equipment, farming equipment such as pumps, cages and tanks and health and natural feed additives.

### Feeds and Ingredients

India's top aqua feed producers were represented at the trade show. The number two leader in shrimp feed **Avanti Feeds Limited** ([www.avantifeeds.com](http://www.avantifeeds.com)) has been gaining market share amongst shrimp farmers in recent years. Its well known Profeed shrimp feed brand has 38% crude protein. A new addition is the Manamei brand for vannamei shrimp with the lower 35-32% crude protein. Both brands are produced in collaboration with Thailand's Thai Union Feedmill Co Ltd. Gold Mohur Foods and Feeds, a division under **Godrej Agrovet** ([www.godrejagrovvet.com](http://www.godrejagrovvet.com)) has Indica feeds for the vannamei shrimp with 38 to 36% crude protein. It has recently started to produce feeds for fish fry and juveniles under the Nutrifry range with 40% crude protein and 20% crude protein sinking fish feeds for the Indian major carps, pangasius catfish and tilapia. The company also has feeds for the freshwater prawn, commonly called scampi in India.

**Indian Solvent Industry**, part of the IB group ([www.ibgroup.co.in](http://www.ibgroup.co.in)) has emerged as a leading producer of extruded floating feeds for the

emerging pangasius catfish in India. The production of the Abis fish feed, a high protein soy based feed is the latest venture for the company based in Chhattisgarh State. Feeds are produced using an 8 tonnes per hour extruder and contain 28-32% crude protein with 2500-2700 kcal energy. **Ananda Enterprises (India)** is a fully integrated company with hatchery, farming, feed production and processing of the pangasius catfish. In feed production, floating and sinking feeds are produced for various freshwater fish and production capacity is 100,000 tonnes per year. Detailed reports on these two companies will be published in the next issue of Aqua Culture Asia Pacific.

Dutch company **Catvis BV** displayed the CV shrimp larval feeds produced in the EU with the latest processing technology and using top quality ingredients. The particulate feeds are for all shrimp species and sizes range from 50 to 400 microns. There are three lines- green, orange and blue, each varying in protein composition. The range is sold through SRV aqua tech Pvt Ltd in India.

**King Fishing Corporation** ([www.kingfishproducts.com](http://www.kingfishproducts.com)) has a 22-year history in producing sterilised fish meal, fish oil and squid meal, based in Veraval, Gujarat in the west coast of India. Export markets are the US, Japan, Taiwan and several south East Asian countries. The raw materials are pelagic mackerels, sardines, and ribbon fish for fish meal and squid viscera portions from cannery plants. The annual production is 800-1000 tonnes of 68% to 70% protein squid meal, 8,000 to 10,000 tonnes of 65% protein fish meal and 700-900 tonnes of fish oil.



*Stefan Khor (right), Advanfis Malaysia was marketing aeration systems*



*Purnomo (left) and Rudi Purwono (right), PT Matahari Sakti, Indonesia at the booth of King Fishing Corporation with Anshul Goel.*



M.C. Nandeeshha exchanging an agreement with Kevin Fitzsimmons

## MOU for Fisheries College and Research Institute, Thoothukudi

Another activity at APA 2011 was the signing of memorandum of understanding (MOU) between the Fisheries College and Research Institute, Thoothukudi with Auburn University, University of Arizona and Virginia Tech University. This will facilitate an exchange of staff and students, undertake education and research programs between these institutions. In the 1960s, Auburn University played a key role in starting the professional degree course in fisheries in Mangalore.

On behalf of Auburn University, Dr. Antonio Garza de Yta, Director of International Relations exchanged documents with Dr. Venkataramani, Director of Research and Extension (Fisheries), representing TANUVAS (Tamilnadu Veterinary and Animal Sciences University). Prof. Kevin Fitzsimmons, Arizona University exchanged an agreement with Prof. M.C. Nandeeshha, Dean of Fisheries College and Research Institute, TANUVAS.

TANUVAS already has a MOU with Virginia Tech University in veterinary sciences. This was then expanded to include an aquaculture component. A MOU was signed and exchanged between Dr. Elankumaran Subbaiah of the Virginia Tech University and Dr. Prabhakaran, Vice Chancellor of TANUVAS.

## Nets and cage technology

**Garware-Wall Ropes Ltd** (GWRL) based in Pune, India is a pioneer in synthetic cordage business in India and is amongst the world's leading manufacturers of synthetic netting, twines and ropes.

The company, established in 1976, is listed on the Indian stock exchange. It provides customised aquaculture cages that are ideal for marine, fresh water and brackish water environment. With its net assembly shop set up in 2002, GWRL commenced fabrication of fully made up nets for cages, and predator and bird protection nets for aquaculture. Currently, it is major supplier of fishing and cage nets for Norway, British Columbia in Canada, Faroe Islands in Scotland, New Zealand and Australia.

The company manufactures a wide range of netting material, knotless as well as knotted in nylon, HDPE, polypropylene multifilament and polyester. Yarns are UV resistant. Fabrication of net cages is done according to designs and dimensions required by customer.

"We introduced the sapphire braided nettings in 2002. Sapphire is high tenacity compact braided HDPE netting particularly used for the towing cages of tuna in South Australia. These superior strength nets have smaller diameter and less weight and lower the drag and resistance leading to a 20% saving on towing costs. However, the texture of this sapphire netting material does not lend well to algae formations. We have a joint market development agreement with DSM Dyneema for South and South East Asia and Oceania. We supply Plateena nets, nets made from Dyneema yarn for trawling, purse seining and for aquaculture cages. Plateena nets are 60% lighter than traditional nylon nets due to its superior strength, and the much thinner twines ensures less algae formation, thereby resulting in a reduction in operational costs, and lessens fish escape" said Gopakumar Menon from the global marketing team.

## Health and nutrition

**Singapore Biotrade** demonstrated a new product Gutacean™ that will significantly boost growth and survival rates of shrimp nauplii with an additional 20% survival even during end of spawning cycle. Post larvae will show better immunity and shorter days of culture. The company said that the product, a mixture of oligoproteins and oligosaccharides leaves no residues after application, as it is natural, plant based and biodegradable. A one-time application for 30 to 60 minutes is required with no changes to the normal hatchery protocol after application. **Virbac Animal Health India** was marketing several specialty products for aquaculture. These included supplements such as Nutrimix to improve liver metabolism in fish and Pro marine, a combination of probiotics, vitamin C and calcium to stimulate better digestion. The company said that Pro marine generally helps with growth and immunity and also helps to protect from problems associated with white faeces disease. Another product is Agrimin, a combination of minerals and DL methionine and L-lysine, calcium and phosphorus.



At the Alltech Biotechnology booth, Ramesh Subramaniam (right) and Vaidehi Venugopalan.

"Marine cage culture is on the rise in India and we have initiated some trials in cage culture for sea bass, with the Central Marine and Fisheries Research Institute, Visakhapatnam in Andhra Pradesh and Karwar in Karnataka. We originally started out with large 15m diameter circular cages in offshore waters. Later when these cages were found to be too large to operate for sea bass culture, the cage sizes were reduced to 6m diameter."

"Our R&D is constantly striving to develop new products based on the requirement of markets and farms. Our current focus is to develop netting and antifouling for aquaculture cages with specific focus on tropical waters. It is important that we look into how biofouling can be delayed and reduce operational costs," said Menon. ([www.garwareropes.com](http://www.garwareropes.com))



Gopakumar Menon (centre) with Zia Butt (right), business development in India and Anith Kumar, assistant branch manager.

# Global seafood shopping

**IFTRA, the international food supply chain management company has its headquarters in Dubai and ten international locations. The company works out of Kampala, Uganda for Eastern Africa, Cairo, Egypt for Western Africa and Romania for Eastern Europe. There are representative offices, spreading from Vietnam, Sri Lanka, China, Japan and Mozambique. In the seafood supply chain, the company markets Nile perch, basa catfish, tilapia fillets and various seafood products.**

“What we do is link seafood from producer to retail and covering capture fisheries and aquaculture,” said Manoj Sreekanta, managing director and also one of three partners in this venture. He was also credited with modernising the seafood retail industry in India. IFTRA was started in 2007 as an integrated food solution company. The target of the company is USD 500 million of sales in 2015.

The company seeks synergies with branding. In seafood marketing as well as with other products, the first level is identification of markets and then trading. In level two, it identifies the product and branding and seeks contract production, both in aquaculture and capture fisheries and processes the products in plants which the company owns. In general, the strategy is to define the market, followed by branding (which is determined by country of origin) and pricing.

“We have specific targets. Eastern and Central Africa forms the importing base for the East Africa Trade Block which has a 75 million population and USD 125 billion GDP. To Central Africa, we bring mackerel and sardines from Japan and Norway. We can export aquaculture products from Uganda to Europe through our newly acquired EU approved processing factory in Kampala, Uganda. Uganda has many large freshwater bodies of 150-200ha including Lake Victoria and we see the potential of cage culture of tilapia. Now we are in the



*Manoj Sreekanta (right) and Anil Kumar at their booth*

midst of bringing in a team of experts to help us. Tilapia prices are USD 2.50/kg for whole fish and USD 4.00/kg for fillet.

In India, we seek contract farmers to produce vannamei shrimp for domestic markets. My benchmark price is INR 225/kg for the vannamei shrimp and I predict that the shrimp will stay in the domestic market.” More information: [www.iftra.com](http://www.iftra.com)

## Feed ingredients

**After three years in production, Cargill, USA continues to introduce Emyreal®75, the pure protein concentrate made from US corn, as a new ingredient for Asian markets. This new generation high energy corn protein concentrate with 75.6% (as is basis), is marketed as a partial replacement for fish meal at 3-10% inclusion as well as a highly functional lower cost alternative to many animal or marine based protein by-product meals.**

Its presence at the trade show was the first for the marketing team of Bill Achor, director of sales and marketing, Zach Longhini, export manager and Eric Bell, product line manager. Achor explained that the production process includes several steps; removal of the fibre from corn, extraction of the oil, mechanical separation of the starch from the protein component and finally a patented enzymatic process to further concentrate the proteins that results in a functional pure protein with a minimum guarantee of 75% protein and less than 6% carbohydrate.

Currently, the price of the product is almost half of that for fish meal. However, with the current volatility of corn prices, buyers are expected to be concerned. Achor, assured buyers, “Cargill does an excellent job in securing our raw materials, performing thorough risk management assessments. Since we manufacture this ingredient on purpose, it is not a by-product, and so we are able to minimize the volatility that is often associated with commodities. It helps that we



*From left, Bill Achor, Zach Longhini and Eric Bell.*

are able to forecast and secure our raw materials ahead of time.”

The team emphasised that the process includes an added full pasteurisation step, which reduces levels of mycotoxins, thus creating a more functional and safer pure protein ingredient that is highly digestible. Other attributes amenable to extrusion are homogeneity, excellent product binding, ingredient co-mingling and a uniform fine cell structure. Along with this, it has low anti nutritional factors (ANF) in comparison to soybean or rapeseed meal. It is a gluten free option, low in lysine but high in methionine and other amino acids. The production pays attention to current sustainability issues and Achor said that the raw material is ‘wholesome, renewable and of a natural source of protein’. It has the kosher, halal and GRAS status.

The next introduction by the team to the Asian market will be at the Aquatic Asia/VIV Asia 2011 in Bangkok, Thailand from March 9-11. More information: [www.E75aqua.com](http://www.E75aqua.com)

# SMEs in ornamentals

The production and export of ornamental fish are key industries in Malaysia. Since 2006, the biennial Aquafair Malaysia exhibition and technical seminars have been held to showcase the local industry to international and domestic buyers and encourage networking opportunities among producers and buyers. It is also to expose new and existing players to developments in breeding and culture technology, how to be competitive and how to align production to meet domestic and international market demands.



Ornamental fish production is the fastest growing industry in Malaysia's agriculture sector with a 15% annual growth rate. In 2009, production was 632 million tails of more than 250 species of fish, valued at USD 244 million. Production was expected to increase to 800 million tails (USD 256 million) in 2010. The global market for ornamental fish and aquatic plants was estimated at USD 15 billion in 2006, with an annual growth rate of 10% and 15%, according to data from FAO. Asian countries contribute 56% of the global production. Malaysia is the seventh key exporting country for ornamental fish after Singapore, Thailand, Indonesia, Sri Lanka, Spain and the Czech Republic.

This third show in the series was organised by the Department of Fisheries (DOF), and Fairs and Events. It was held in Kuala Lumpur from November 25-28 2010 where there were more than 100 local and international companies featuring a range of products from ornamental fish and plants to aquarium equipment.

## Newcomers

A noteworthy addition to this year's show was the participation of small and medium enterprises (SME) from all corners of the country. In the last few years, the number of small companies involved in ornamental fish production has mushroomed as government and state agencies push for entrepreneurship in the industry. New producers were encouraged with low entry barriers and high profit margins (at least 40%) from holding or breeding ornamentals with a short grow out cycle. The ornamental fish industry is the focus of development with a target production of more than 938 million tails in 2011 with a value of MYR1.06 billion, according to the director general of Fisheries, Malaysia, Datuk Ahamad Sabki Mahmood.

The company, **Integrated Bumi Aquarium Express (iBAE)**, calls itself the first Malaysian 100% biosecure fish farm. In a 0.4ha site, the company breeds more than 50 varieties of fish in a totally enclosed indoor facility in contrast to other fish farms which use outdoor ponds and tanks (usually cement, earthen or fibreglass). The company was



set up two years ago by a group of breeders, exporters and importers. It is based in Port Dickson, in Negri Sembilan in Peninsular Malaysia.

iBAE also collects fish from local breeders and from those in Indonesia and Thailand. These are quarantined and re-exported mainly to Eastern Europe, Belgium, France, Italy, Germany, Middle East, Iran, Jordan and Syria. The main species are cardinal, angel fish, long-finned neon tetra and planet catfish.

"Our biosecure farm is ahead of others in the country. It is not an issue for exports to the European markets except for the koi and goldfish (*Cyprinidae*) because of a EU suspension on imports from Malaysia. Malaysia has a good climate for ornamental fish operations and costs are low in comparison with Singapore. We are bullish in the business and especially in the European and local markets. Our aim is to be among the top breeders in the country" said Dato' Saipuddin Ahmad, executive chairman of iBAE.

## Marketing the arowana

The eight-year old company, **Kulim Aquaculture**, started with the trading of the arowana, *Scleropages formosus*. It has now diversified

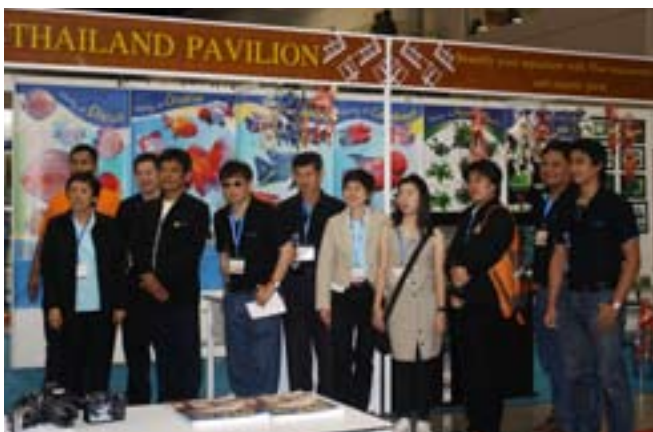

Dr Amornrat Sermwatanakul (left) with her team at the Thailand Pavilion.



Dato' Saipuddin Ahmad, showing his certificate

into its breeding with 100 ponds occupying 4.8ha. The company has also entered the food fish segment with a tilapia hatchery to supply local grow-out farms and production of the marble goby, *Oxyeleotris marmorata* in 50 ponds. "The reason for the diversification is the business stability of the food fish segment. Ornamental fish production is very competitive" said Zulkifli Zarkasi.

"The demand for the arowana fish changes with the species and season. For example, during this Aquafair Malaysia 2010, the demand is for the Red and High Back arowana. Latin America is the major supplier of Silver arowana but supply is seasonal. We have been producing the arowana fish in our ponds in Bukit Merah, the original source of the Malaysian Golden arowana. We mainly target the local market where we sell the fish through our shops. Now with excess production, we are seeking export markets and initially will target the Middle East."

**Bukit Merah Aquaculture (BMA)** was started in 2000 by Abdul Rahim Che Meh, director, and Ahmad bin Don, managing director. Currently, they are breeding eight different species of arowana; Malaysian Golden, Blue Base, Chili Red, Banjar Red, Super Red, Green, High Black and Silver arowana.



Abdul Rahim Che Meh, Bukit Merah Aquaculture

The company has more than 1,000 ponds occupying 40ha in Bukit Merah and Kuala Kangsar, Perak, peninsula Malaysia. Usually they culture 16-20 brood stock in one pond. Every two months, they will check for spawning brood stock. BMA sells more than 1,000-2,000 arowana fingerlings to the domestic and overseas markets such as China, Hong Kong, Singapore and Vietnam. Larger size fingerlings (4-5 inches) are exported whilst the smaller size (2-3 inches) are meant for the local market.

"At the show, we are marketing arowana alongside some of Malaysia's top producers, such as **Arowana Dragon** and **King Kong Aquarium Importers and Exporters**. Competition is also from Thailand, even though it is a small producer. The forte of Indonesian producers is the original Red arowana. BMA has produced a new hybrid, Mas Merah which is a cross of the Malaysia Golden and Super Red. However, the original Malaysia Golden Arowana has higher demand and better value. Nevertheless, quality is a priority for BMA and we plan to expand by 24ha in Kuala Kangsar and in five years, we hope to expand this business to the Middle East and Europe," said Abdul Rahim.

## Betta breeder

In the northern state of Kelantan, Mohd Zulkifli Yusoff has developed from what was a hobby into a profitable business. In his backyard hatchery in Kg. Hulu Beta Jias, Kota Baru, Kelantan, Mohd Zulkifli now breeds the guppy and betta. He has received an overwhelming response for his betta fish at the show and has an order for more than 500,000



Mohd Zulkifli Yusoff (middle) with Universiti Putra Malaysia student Che Mohd Taufik Che Rusle (left) and visitors at the booth.

tails a month. Besides the betta, Mohd Zulkifli is also breeding the molly, platy, discus and angel fish. Currently the focus is the retail market in Kelantan and neighbouring Terengganu. However, he has not ruled out the possibility of expanding to markets in other states.

"I have recognised that this is not an easy business. Firstly, I needed the experience to be able to succeed in fish breeding. It took me 4 years to learn the basic techniques of breeding before I decided that this would be my rice bowl".

He added, "Although the discus fish is beautiful and marketable, its rearing and culture is a challenge especially with disease and water quality. However, we are successful and it is a profitable business. The discus can be marketed in 2 months after hatching at an average size of 2 inches. One female fish can produce as many as 100 eggs at a single spawning but not all fry are of the A grade."



Zulkifli Zarkasi at the Kulim Aquaculture booth.

## Exporting Thailand's koi and gold fish

Whilst Malaysian producers have the edge with the arowana, Thai producers have an advantage with exporting the koi and goldfish produced by premium producers to EU markets with high prices. In order to export these fish, these farms must first pass the regulations set by the Department of Fisheries (DOF), Thailand. At the Thailand pavilion, Dr Amonrat Sermwatanakul, explained the regulations for farms in exporting of ornamental fish from Thailand.

"The farm must be registered with DOF, Thailand; for live ornamental fish, it must have Good Aquaculture Practices (GAP) certification. It also needs to pass sanitary inspection for OIE listed diseases. Exports are only for approved farms and in the case of the koi, premium farms routinely monitor for KHV (koi herpes virus) and SVC (Spring viraemia of carp) viruses with PCR and report to the Department of Fisheries regularly".

"Our next step will be to introduce the compartment system, which could be an EU requirement in the future."



# Disease prevention in cultured marine fish by Jia Yin Du

Published by JinDun Beijing China in 2007, 2009 and 2011  
267pp. Language: Chinese.

This book, written by the well-known fish disease scientist, Jia Yin Du of Dalian Ocean University (Former Dalian Fisheries University) is in its third print. In chapter one, he introduces the progress in research of new infectious diseases on cultured marine fish. It is followed by chapters on the common parasitic disease, bacterial disease and viral disease of Bastard halibut *Paralichthys olivaceus*, turbot *Scophthalmus maximus*, Red sea bream *Pagrus major*, Japanese sea perch *Lateolabrax japonicus*, Yellowtail *Seriola quinqueradiata*, Greater amberjack *Seriola dumerili*, Striped jack *Caranx delicatissimus*, Jacopever rockfish *Sebastes schlegeli*, Greenling *Hexagrammos otakii*, Coho salmon *Oncorhynchus kisutch*, Atlantic salmon *Salmo salar*, Tiger puffer *Takifugu rubripes*, Bluefin tuna *Thunnus thynnus* and their prevention technology. Chapter 8 is an introduction on the diagnosis and management of toxic red tides.

This book encompasses the author's many years of field studies and on-the-spot disease diagnosis and treatment experiences. It also covers many of the latest research achievements and practical culture technologies in countries like Japan, Norway, Chile, and Spain. It was written as a standard text and is intended for teachers and students in fisheries and aquaculture, workers in aquatic farms and fish disease researchers.

The book is available from the Distribution Centre: JinDun Beijing China, Email: JiaYinDu@163.com; Fax/Telephone :+86 411 8469 2541. The list price is RMB 15.

Reviewed by XinXinDu, Email: duxinxin12@163.com

## President of FEFAC to open annual event

**At a recent press gathering, Henk van de Bunt, Victam International announced that the President of FEFAC, the European Feed Manufacturers Federation, Vanden Avenue, will participate at the official opening ceremony of the new FIAAP, Victam & GRAPAS International 2011 exhibitions and conferences.**

"It will be four years since the last Victam International Exhibition and a lot has happened within the industries that this world famous exhibition serves. This will be reflected in this new event – there will now be three trade shows within the exhibition hall and seven different conferences for the international delegates to attend," said van de Bunt.

"Victam International 2011 will be held from 3 – 5 May 2011 in Cologne, Germany. The new home for the event will be the largest exhibition hall within the Koelnmesse in Cologne, Germany. Hall 6 of Koelnmesse is their newest hall. The last show was held in 2007, in Utrecht in The Netherlands. This year our exhibitors have an enormous range of products on display from almost 300 exhibiting companies and from 28 countries.

"Victam International is now the largest exhibition in the world for animal feed processing technology and systems. Our visitors will see the latest specialist appropriate technology that is used in the safe and cost effective manufacture of animal and aqua feeds as well for dry petfood. There will also be a wide selection of companies that supply the 'nuts & bolts' equipment that are so necessary for a modern and efficient production plant and distribution system. These include silos, conveyors, IT, magnetics, coolers/dryers, bagging systems, trucks, and much, much more."

FIAAP is the new trade show with conferences organised specifically for ingredients, additives and formulation technology used within animal feed, aquafeed and dry petfood processing. Exhibitors will be displaying a wide range of feed ingredients, feed additives, formulation programs, laboratory and quality control equipment.

GRAPAS is also a new exhibition and conference and is for flour milling, grain processing, storage & preservation, pasta, breakfast cereal and extruded snack production. Visitors will be able to see a wide range systems and equipment used in these production processes and will include: flour & rice milling technology, extruders, flakers, additives & flavours, etc.

Again as with all production plants ancillary equipment is required to supplement the specialist technology - dust explosion prevention systems, silos, conveyors, elevators, magnetics, coolers/dryers, instrumentation & automation, bagging systems, to name a few. All of these and more will be on display at the exhibition in Cologne.

For the aquafeed industry, Aquafeed Horizons will be held on Tuesday 3 May. During the exhibition a series of technical seminars will be held every day. These will be presented by a number of different exhibitors covering a wide range of subjects. The final program of these technical seminars will be made available shortly on the Victam website.

Organisers have also introduced a new visitor registration system. All a visitor needs to do is visit the website [www.victam.com](http://www.victam.com), click on "visitor registration" and then complete the online form to receive an automated confirmation of their FREE visitor registration. The printed confirmation must be presented to the receptionists at the desk marked "Pre-Registered Visitors" and there they will receive their entrance badge. This badge will allow entrance to all three shows.

# The Shrimp Book

By Zuridah Merican

Edited by V. Alday-Sanz; Nottingham University Press; 920 pages, ISBN 978-1-904761-59-4



We might expect a book on shrimp farming to deal only with production systems but any shrimp professional will agree that the starting point is understanding the shrimp itself. This and other essential knowledge are given in the 33 chapters written by 67 authors. In her introduction, Alday-Sanz said that her initial task was to develop a book on health and disease in commercial shrimp farming but discovered that this would require not only information on shrimp biology but also culture and management and thus the list of topics increases. Furthermore, similar to what any shrimp professional will attest to, information on all these areas of shrimp farming is usually fragmented in specialised academic journals and trade magazines.

The book is a mélange of topics on what constitutes shrimp farming. It starts with the first chapter on the history of farming, a treatise on 'how did we get here', by George Chamberlain. Then it is divided into several sections; the shrimp, production systems, feeds and feeding, biosecurity and health management, and post harvest and trade issues. The four chapters in the shrimp section which gives us essential information on functional anatomy, integument of shrimp, shrimp immune system and genetics are compilations of research and scientific information. The shrimp immune chapter is particularly useful as the subject is usually detailed in scientific journals.

The more practical information in production systems deals with semi-intensive and intensive culture and nursery systems, including bio-floc technology; maturation and selective breeding of the white shrimp; certification and the White Spot and Taura syndrome viruses. The feeds and feeding section which covers chapters on practical feed management, raw materials to basic information on nutrient requirements provides readers with current knowledge on nutrition. The chapter on nutrient requirements and current status of shrimp nutrition research lends credence to the purpose of the book when the authors said that 'current knowledge is satisfactory for shrimp growth but little is known of the beneficial effects of nutrition on immune

responses in the face of spreading epizootics such as TSV, WSSV and IMV etc.'

The chapter on biosecurity and health management comprises a third of the book and rightly so, considering this has been a challenge since the 1990s. In two chapters, the principal diseases in shrimp farming are discussed; one chapter gave the general information on diseases whilst the other by Timothy W Flegel, looked at host viral interactions to derive at future research directions. In two chapters, a more practical approach to disease management is given. Alday-Sanz gave her personal review on biosecurity design and Su Chen and colleagues from Taiwan focused on using the PCR for disease diagnosis.

On opening the book, we may be in awe at the extent of information required for a successful shrimp business but gradually we see that the information in this book is not rocket science. We will also notice that the coverage veers towards the white shrimp, *Penaeus vannamei* and does not cover in such intensity, work on *P. monodon* or other farmed species. However, this can be related to the work of the authors or that it reflects what we know on the white shrimp as opposed to the monodon shrimp. One will also notice the divergent styles by the authors and the repetition of some information. The editor explained that this was a deliberate editorial policy in view of the different nationalities of authors and their personal experiences. Nevertheless, with this one book, we now have a comprehensive coverage on shrimp farming to move the industry from an art to a science. The book is recommended as an essential reference, from the student learning more on shrimp aquaculture, to shrimp professionals, policy makers and researchers.

More information: Price £200.00; Web: [www.nup.com](http://www.nup.com); Email [website@nup.com](mailto:website@nup.com)

## What can you expect from Aqua Culture Asia Pacific in 2011

Volume 7 2011						
Number	1 - January/February	2 - March/April	3 - May/June	4 - July/August	5 - September/October	6 - November/December
<b>Issue focus</b> Recent developments and challenges for the next step	Aqua Feed Production	Cage Culture	Sustainable & Responsible Aquaculture	Health Management	Hatchery	Food Safety & Traceability
<b>Industry Review</b> Trends and outlook	Marine Shrimp	Groupers	Catfish	Tilapia	Freshwater Fish/Prawn	Marine fish (Cobia/Sea bass)
<b>Feeds &amp; Processing Technology</b> Technical contributions influencing the final value of aqua feeds	Additives/ Protein meals Processing Technology	Micro-nutrients /Vitamins & Minerals Extrusion	Feed Enzymes/Lipids Post Pellet Additions	Nutritional Health Feed Management	Feed Probiotics Drying Technology	Novel Feed Ingredients/ Nutrition
<b>Production Technology</b> Technical information and ideas	Biofloc Technology	Breeding and Genetic Improvement	BMP, Standards and Certification	Recirculation Aquaculture Systems	Hygiene & Food Safety	Health Management & Biosecurity
<b>Aqua business</b> Feature articles	Experiences from industry, including role models, benchmarking and opinion articles in shrimp/fish culture					
<b>Markets</b>	Market trends, product development and promotions at ESE 2011, Vietfish 2011 and regional trade shows					
<b>Show Issue</b> Distribution at these and regional events (TBA) *Show preview	VIV Asia 2011/Aquatic Asia 2011, Bangkok, Thailand 9-11 March*	9th Asian Fisheries and Aquaculture Forum & ISTA 2011, Shanghai, China, 21-25 April*	Vietfish 2011, Ho Chi Minh City, Vietnam 28-30 June  World Aquaculture 2011, Natal, Brazil 6-10 June	TARS 2011 - Aquaculture Feeds and Nutrition, Singapore August 17-18	Aquaculture Europe 2011, Rhodes, Greece 18-21 October  16th China Seafood & Fisheries Exposition & Aquaculture China 2011, Qingdao, China, 1-3 November	Third International Symposium On Cage Aquaculture in Asia, Kuala Lumpur, Malaysia 16-19 November



# Third International Symposium on Cage Aquaculture in Asia (CAA3)

16 to 19 November 2011, Kuala Lumpur, Malaysia

This is a follow up to the Second International Symposium on Cage Aquaculture in Asia (CAA2), held in Hangzhou, China in 2006, organised by the Asian Fisheries Society. This symposium in Kuala Lumpur will be co-organised by the Malaysian Fisheries Society and Department of Fisheries, Malaysia. It will continue to look at the commercialization of cage aquaculture in Asia which is increasing rapidly. Cage aquaculture will continue to be a significant contributor to the Asian production of freshwater and marine fin fish but the pressure will be on improving efficiencies in production. The symposium will be an opportunity for industry to learn about developments in other regions and for scientists and all stakeholders to exchange views and network.

The organisers have identified the following sessions and participants are invited to present papers and posters. The deadline for abstract submission is July 31 2011. There will also be a special session covering Seafood Trade & Certification and a Farmers' Day for the local industry.

- Site selection, environmental management & climate change
- Species selection and seed production
- Feeds and feeding
- Biosecurity and health management
- Production technology and systems
- Economics, markets and certification
- Policy and regulations

There will be a trade show, which will bring local and international exhibitors and manufacturers together to show-case the latest in cage and feeding technology and innovations. More information: email: [caa3@asianfisheriessociety.org](mailto:caa3@asianfisheriessociety.org); Web: [www.asianfisheriessociety.org/caa3](http://www.asianfisheriessociety.org/caa3)



## MISE 2011

During CAA3, there will be the Malaysian International Seafood exposition (MISE2011) which will run from 18 to 20 November. This second exhibition follows the success of the inaugural exposition in 2009 at the same venue. MISE 2011 is organised by the Department of Fisheries. The aim is to showcase seafood products from Malaysia and create opportunities for the sector in Malaysia to expand in both domestic and export markets.

### March 31-April 1

#### 12th Aquaculture Insurance & Risk Management Conference

Kinsale, Co Cork, Ireland

Email: [info@aums.com](mailto:info@aums.com)

Web: [www.aquacultureinsurance.com](http://www.aquacultureinsurance.com)

### April 21-25

#### 9th Asian Fisheries and Aquaculture Forum & 9ISTA-International Symposium of Tilapia Aquaculture

Shanghai, China

Web: [www.9afaf.org](http://www.9afaf.org)

Web: <http://ag.arizona.edu/azaqua/ista/ISTA9/ISTA9.htm>

### May 3-5

#### Victam International 2011

Cologne Germany

Web: [www.victam.com](http://www.victam.com)

### May 3-5

#### European Seafood Exposition/Seafood Processing Europe

Brussels, Belgium

Email: [food@divcom.com](mailto:food@divcom.com)

Web: [www.euroseafood.com](http://www.euroseafood.com)

### May 22-25

#### Alltech's 27th Annual International Animal Health and Nutrition Symposium

Lexington, Kentucky, USA

Web: [www.alltech.com/symposium](http://www.alltech.com/symposium)

### May 26-29

#### 12th International Ornamental Fish and Accessories Exhibition (Aquarama 2011)

Singapore

Email: [aquarama-sg@ubm.com](mailto:aquarama-sg@ubm.com)

Web: [aquarama.com.sg](http://aquarama.com.sg)

### June 6-10

#### World Aquaculture 2011

Natal, Brazil

Email: [worldaqua@aol.com](mailto:worldaqua@aol.com)

Web: [www.was.org](http://www.was.org)

### June 14 - 16

#### International Scientific Conference on Probiotics and Prebiotics - IPC2011

Kosice, Slovakia

Email: [info@probiotic-conference.net](mailto:info@probiotic-conference.net)

Web: [www.probiotic-conference.net](http://www.probiotic-conference.net)

### June 28-30

#### Vietnam Fisheries International Exhibition (Vietfish) 2011

Ho Chi Minh City, Vietnam

Web: [www.vietfish.com.vn](http://www.vietfish.com.vn)

### August 17-18

#### TARS 2011 - Aquaculture Feeds and Nutrition

Singapore

Email: [conference@tarsaquaculture.com](mailto:conference@tarsaquaculture.com)

Web: [www.tarsaquaculture.com](http://www.tarsaquaculture.com)

### August 17-18

#### Aquanor Forum (during AquaNor 2011)

Trondheim, Norway

Email: [aqn2011@aquaculture.cc](mailto:aqn2011@aquaculture.cc)

Web: [www.easonline.org](http://www.easonline.org)

### September 16-18

#### 6th Strait (Fuzhou) Fishery Expo

Fuzhou, Fujian, China

Email: [xmcdw@163.com](mailto:xmcdw@163.com)

Web: [www.fishexpo.cn](http://www.fishexpo.cn)

### October 18-21

#### Aquaculture Europe 2011

Rhodes, Greece

Email: [Registration:worldaqua@aol.com](mailto:Registration:worldaqua@aol.com)

Trade: [mario.stael@scarlet.be](mailto:mario.stael@scarlet.be)

Web: [www.easonline.org](http://www.easonline.org)

### 26-28 October 2011

#### Aquamar Internacional IX Expo

Sonora, Mexico

Email: [zola\\_lopez@aquamarinternacional.com](mailto:zola_lopez@aquamarinternacional.com)

Web: [www.aquamarinternacional.com](http://www.aquamarinternacional.com)

### November 1-3

#### 16th Annual China Fisheries & Seafood Expo 2011

Qingdao, China

Email: [seafoodchina@seafare.com](mailto:seafoodchina@seafare.com)

Web: [www.chinaseafoodexpo.com](http://www.chinaseafoodexpo.com)

### November 16-19

#### Third International Symposium on Cage Aquaculture in Asia

Kuala Lumpur, Malaysia

Email: [caa3@asianfisheriessociety.org](mailto:caa3@asianfisheriessociety.org)

Web: [www.asianfisheriessociety.org/caa3/](http://www.asianfisheriessociety.org/caa3/)

### November 21-25

#### Eighth Symposium on Diseases in Aquaculture

Mangalore, India

Email: [kalkulishankar@gmail.com/mircen@sanchartnet.in](mailto:kalkulishankar@gmail.com/mircen@sanchartnet.in)

Web: [www.daa8.org](http://www.daa8.org)



Illustration/Design: Capamara Design

# MEDITERRANEAN AQUACULTURE 2020

OCTOBER 18-21, 2011

RODOS PALACE LUXURY CONVENTION RESORT

RHODES, GREECE

[WWW.EASONLINE.ORG](http://WWW.EASONLINE.ORG)



AQUACULTURE EUROPE - THE ANNUAL MEETING OF THE EUROPEAN AQUACULTURE SOCIETY.





# CREATES THE VALUE OF PRAWN



Uni-President implements traceability through all sectors along with supply chain. Biosecurity hatchery produces SPF (Special Pathogen Free) and SPR (Special Pathogen Resistant) larvae. Quality program of prawn feed plants was certified by ISO 22000 & HACCP.



• 16-TB, DT 743, Song Than II Industrial Zone,  
Sinh Duong, Vietnam.  
• Tel: +84-450-3737626 - Fax: +84-450-3790819  
• Email: [ugp@upvn.com.vn](mailto:ugp@upvn.com.vn)



CTY TNHH UNI-PRESIDENT VIỆT NAM  
UNI-PRESIDENT VIETNAM CO., LTD.

Establishing a Healthy and Happy Tomorrow